

Installation of the Mr.Steam® Steam Head (1/2" NPT, PN 103937) with Acrylic Shield (PN 103938)

The Acrylic Shield (PN 103938) is for use when acrylic or other non-heat resistant materials are used for the steamroom enclosure.

CAUTION INSTALLER: Because the steam head and direct steam emissions are very hot, locate the steam head where incidental contact by bather with the steam head or direct steam emission cannot occur.

CAUTION These instructions are only for use in installations using an Acrylic Shield (PN 103938).

STEP 1

Locate steam head 6-12 inches above floor, except for Tub/shower enclosures, install 6 inches above tub top edge. The steamhead shall be installed with the oil well facing up as shown. Hand tightening is sufficient when teflon or equal pipe thread sealing compound is used.

IMPORTANT NOTE: to preserve steam head finish, do not use wrench or other tools to tighten. DO NOT use abrasive cleansers or chemicals. Use only water with mild soap and a non-abrasive sponge.

CAUTION Consult with supplier of acrylic, fiberglass and other non-heat resistant enclosures for recommended steamhead location.

STEP 2

Secure a bronze drop ear fitting to a header and run a 1/2" copper steamline from the steam generator to the drop ear fitting. Install a temporary nipple (6" or longer) in the drop ear fitting to locate the steamhead after the wall is finished.

STEP 3

After the wall has been finished, mark on the nipple where the surface of the wall is. Remove the nipple and measure the portion that was in the wall (the end to your mark). Subtract 1/8" from that dimension and select a brass nipple of that length to finish the installation.

STEP 4

Wrap teflon tape around the threads of the new nipple and screw the nipple into the steamhead. Do not use wrenches or tools which would damage the steamhead's finish.

Slide the acrylic shield onto the nipple-steamhead assembly so the steam head sits in the acrylic shield.

Apply clear silicone in the groove on the back of the acrylic shield.

Wrap teflon tape around the threads of the nipple and screw the nipple and steamhead assembly you just made into the drop ear fitting in the wall. The steamhead should be flush with the wall and the well must be facing up.

The acrylic shield will be sandwiched between the wall and steam head.

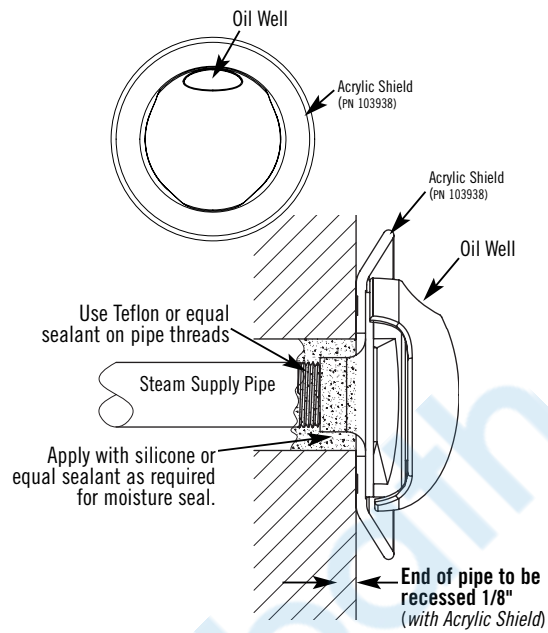

STEP 2

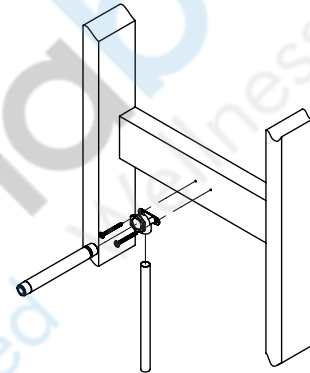

STEP 3

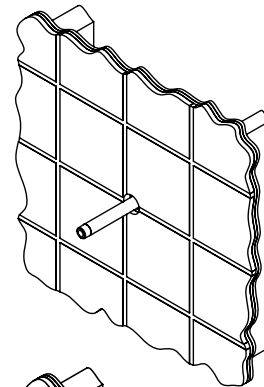

STEP 4

