

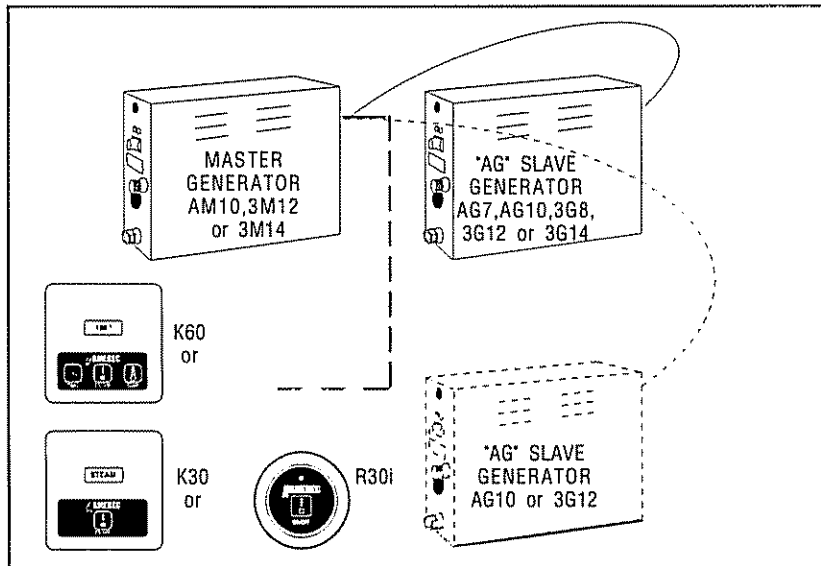

AR or AK 17, 20, 30, 3K20, 3K24, 3K28 & 3K36 System Installation and Service Instructions



AMEREC STEAMBATH GENERATORS MODELS AR17, AR20, AR30, AK17, AK20, AK30, 3K20, 3K24, 3K28 & 3K36

(AM "MASTER" GENERATOR TO BE GANGED WITH ONE OR TWO
AG "SLAVE" GENERATORS)

AR17 & AK17 = AM10 + AG7 + Appropriate Control Kit

AR20 & AK20 = AM10 + AG10 + Appropriate Control Kit

AR30 & AK30 = AM10 + (2) AG10 + Appropriate Control Kit

3K20 = 3M12 + 3G8 + Appropriate Control Kit

3K24 = 3M12 + 3G12 + Appropriate Control Kit

3K28 = 3M14 + 3G14 + Appropriate Control Kit

3K36 = 3M12 + (2) 3G12 + Appropriate Control Kit

**SAVE THESE INSTRUCTIONS. READ ALL INSTRUCTIONS
CAREFULLY BEFORE INSTALLATION.**

SECTION 1: GENERAL INFORMATION

AMEREC Steam Generators are listed by Underwriters Laboratories. The Steam Generators come assembled and ready for installation. Check that the size and rating of the Generator is suitable for your application, refer to the Steam Room Construction and Generator Sizing Guide (AMEREC document 4211-33).

The AG and 3G line of AMEREC Steam Bath Generators are Slave Generators which can not operate as a stand alone individual Generators. Slave Generators are controlled by an AM or 3M Master Generator. Up to two Slave Generators can be "ganged" onto or controlled by a single Master Generator. The sole purpose of ganging is to increase the volume of steam generated without additional controls. Control signals are passed from the Master Generator to the Slave Generator(s) via the cable provided with the Slave Generator. The Slave Generator exactly mimics the Master Generator. What is a Master Generator? It is an AMEREC AM or 3M Steam Bath Generator upgraded with AR or AK Control Options.

IMPORTANT

An exhaust fan installed outside the steam room is strongly recommended to remove excess steam from the bathroom or shower area.

WARNING

*Electrical grounding is required on all
AMEREC Steam Bath Generators.*

*All electrical supplies should be
disconnected when servicing Generator.*

*All wiring must be installed by a licensed
electrical contractor in accordance with
local and national codes.*

*All plumbing must be installed by a
licensed plumber in accordance with local
and national codes.*

Generators are for indoor use only.

*Generators are not for space heating
purposes.*

*Be certain that steam bath enclosures are
properly sealed to avoid water damage
from escaping steam. It is recommended
that 100% silicone caulk be used to seal all
pipes and fittings. Steam must be
prevented from escaping into the wall
cavity.*

*Never shut off the water to a Steam
Generator that is in use.*

*Do not touch the steam heads or trim during
operation as they are hot. Stay at least 12
inches away from the hot steam escaping
from the steam head.*

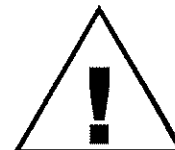

DIAGRAM 1: PREFERRED INSTALLATION

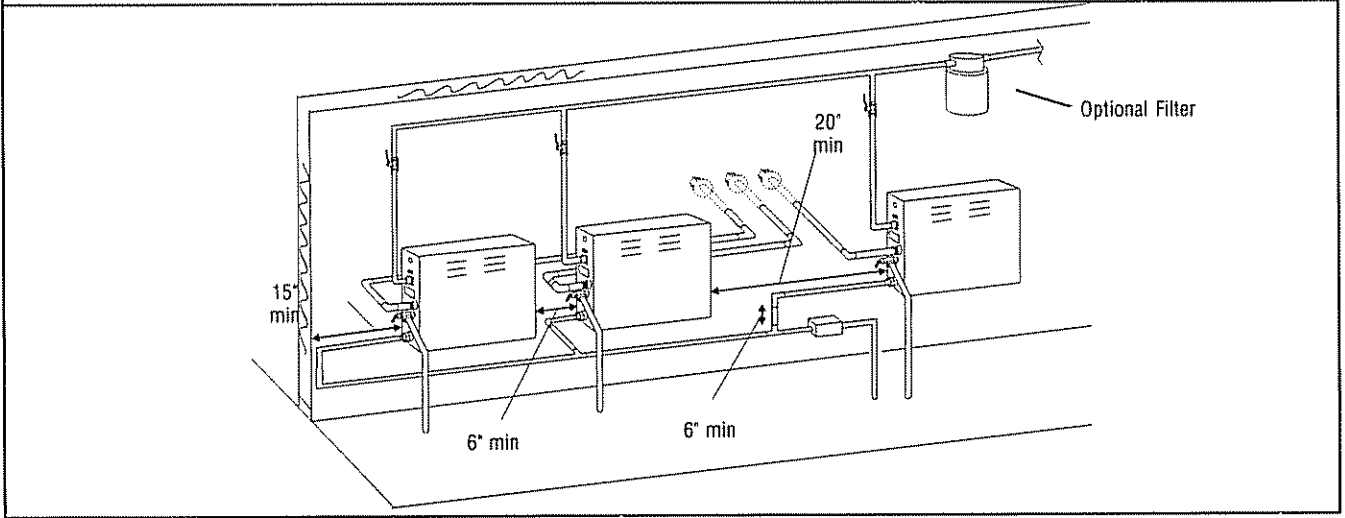

DIAGRAM 2

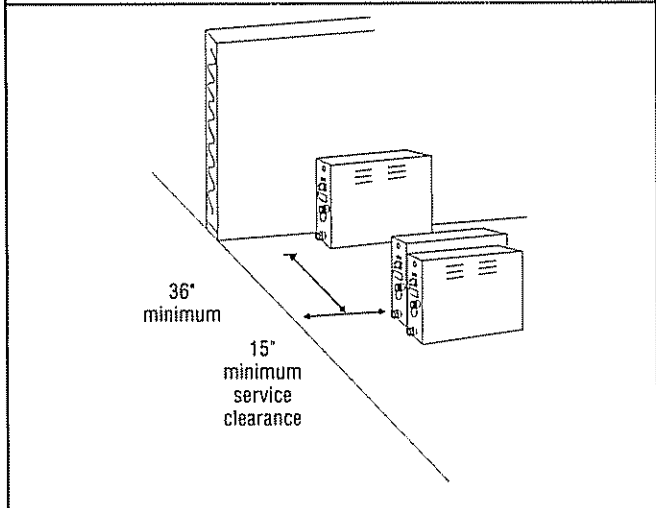

DIAGRAM 3

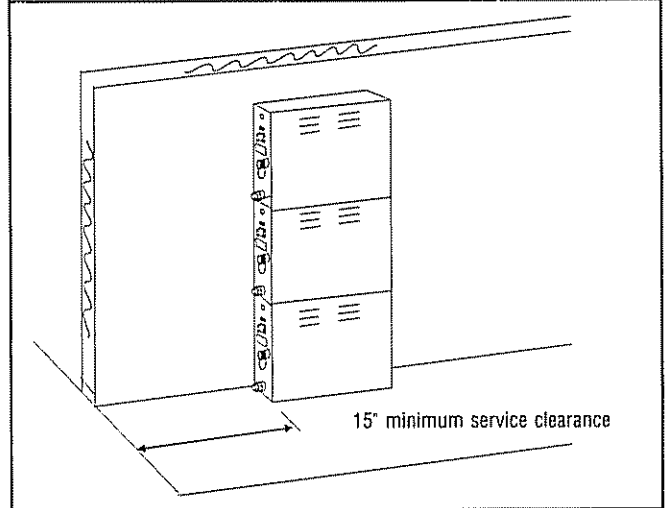

DIAGRAM 4

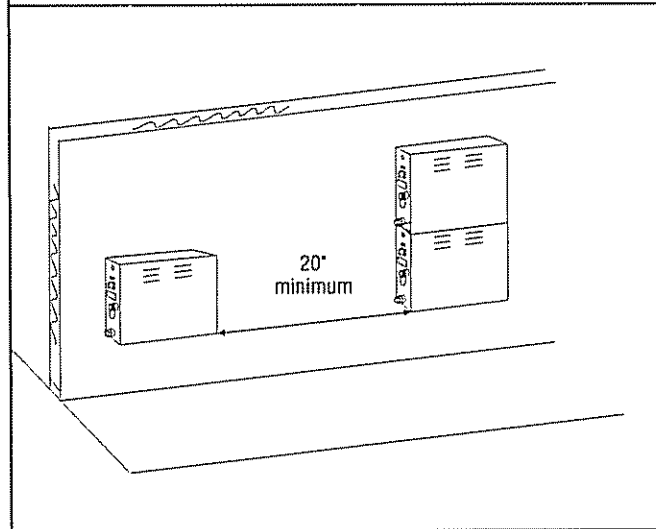
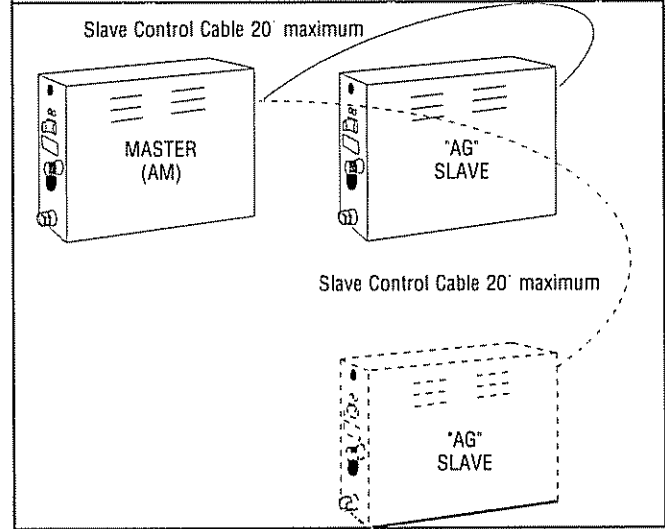

DIAGRAM 5



SECTION 2: SELECT MOUNTING LOCATION

SEE THE PREFERRED DIAGRAM 1 & DIAGRAMS 2, 3, 4, 5 & 15.

IMPORTANT

Prior to making a decision on the mounting location, please read through this Installation and Service Instructions Manual completely and take a careful look at all the diagrams.

The AMEREC Steam Generator can be hung on a wall or set on its base

The best mounting location will satisfy all or most of the following:

1. The steam line must slope to allow condensation to drain. Condensation should drain into the steam room
2. The steam line should be less than twenty (20) feet long. Ten (10) feet is preferred. Steam lines over twenty (20) feet long should be insulated
3. The mounting location should minimize the number of bends and elbows in the steam line.
4. The steam line should enter the room at least 12" above the floor or at least 6" above a tub rim or ledge. See Diagram 14
5. No steam head shall be more than thirty (30) inches above the floor
6. The steam outlet should be located to avoid potential user contact.
7. The Generator(s) should be installed in a dry, well ventilated area. The space provided should be at least:
7 cu ft for one Generator,
17 cu ft for two Generators and
27 cu ft for three Generators.

IMPORTANT:

- Insulate all steam lines and drain lines within the enclosed space.
- Each Generator must be provided with at least four (4) inches ventilation and control wiring access at the control end.
- Each Generator must be provided with at least twelve (12) inches clearance in FRONT of the louvered front cover.
- There should be at least thirty-six (36) inches in front of each Generator for service access.

Suggested locations are under a vanity, in a closet, attic, crawl space or basement. Preferably in the same room.

8. For minimum distance between Steam Generators, see Diagram 1, 2, 3 & 4.

9. The mounting location must be within a cable length of the Master Generator. See Diagram 5

NOTE:

Longer Slave control cables are available. Call AMEREC Service Department at 1-800-331-0349

10. The location should provide clearance for service and element removal. See Diagrams 1, 2, 3 & 4

11. There should be no more than three (3) 90° bends and ten feet of pipe between any Generator's drain outlet and its drain valve inlet. See Diagram 15

WARNING

*Do not mount outdoors.
Protect from freezing.*

To reduce the risk of explosion, do not interconnect steam outlets. A separate steam line must be provided for each steam outlet.

Units must be located as to allow access for service.

DIAGRAM 6

not used

DIAGRAM 7

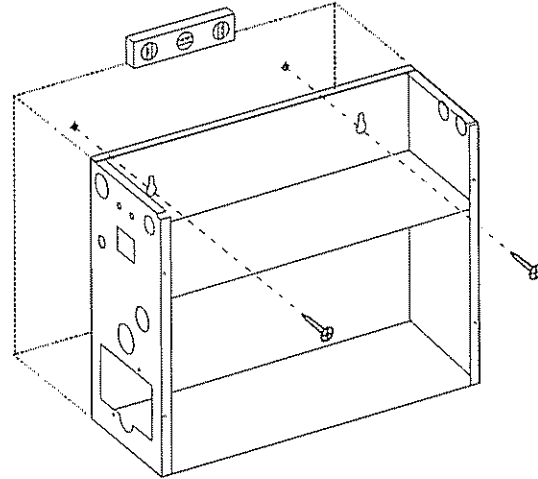

DIAGRAM 8

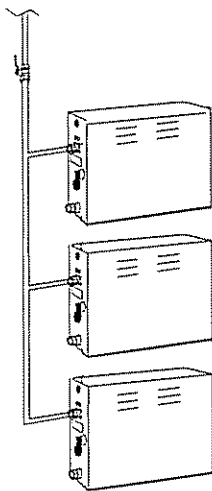

DIAGRAM 9

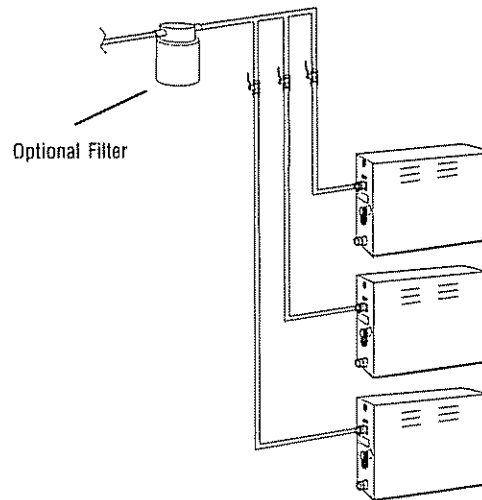

DIAGRAM 10

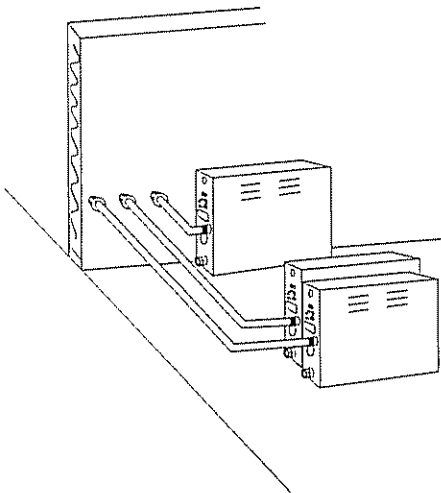
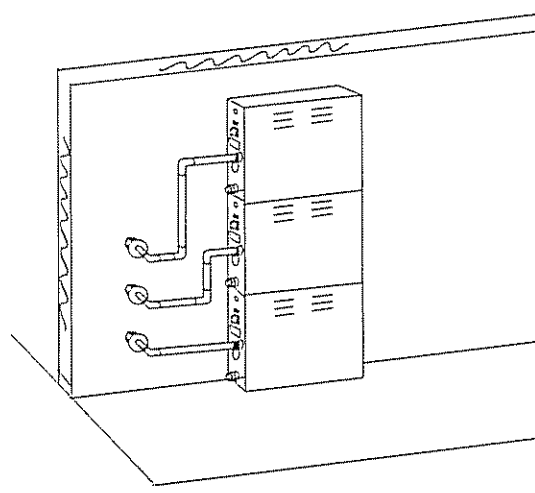

DIAGRAM 11



SECTION 3: NOT USED**SECTION 4: MOUNTING THE GENERATOR**

SEE DIAGRAM 7.

Wall Mounting:

1. Note the location of the mounting holes on the back of the Generator. The screws must set directly into studs or equivalent supports. Drill pilot holes on 16" centers and install the two #10 1-1/2 inch screws provided. See Diagram 7.
2. Carefully hang the Generator on two screws. Tighten the screws. Replace the front cover. Secure the front cover with six (6) screws.
3. Mounting should be level.

Floor Mounting:

1. In general the width of the unit allows it to sit on a shelf, across the ceiling joists or on a floor. The Generator must be restrained from moving. Normally the piping will provide adequate support. If not, additional support must be provided.
2. All floor installed Generators must have provision for routine draining of the tank.
3. Mounting should be level.

SECTION 5: PLUMBING INSTRUCTIONS

All plumbing shall be installed by a licensed plumber and conform with local & national codes.

Materials (locally available):

- 3/8 inch O.D. copper tube for the water supply to the Generator
- 3/8 inch water supply shut-off valve
- 3/8 inch supply housing and filter (optional, depending on local water conditions)
- 3/8 inch O.D. compression to 3/8 inch male NPT adapter.
- 3/8 inch O.D. union
- 1/2 inch copper sweat unions (2)
- 1/2 inch male NPT sweat adapter (2)

- 1/2 inch copper pipe for the tank drain
- 1/2 inch copper pipe and 1/2 inch male NPT sweat adapter (5) for the steam line between the Generator and the Steam Room, and the drain line between the Generator and the drain
- 3/4 inch copper pipe, 3/4 inch male NPT sweat adapter, and a sweat union for the Pressure Relief Valve drain.
- Tube DAP 100% silicone caulk
- Rectorseal No 5 pipe compound

NOTE:

Additional materials will be required if ganging the drain outlets.

SECTION 5A: INSTALL THE WATER LINE

SEE PREFERRED DIAGRAM 1 AND DIAGRAMS 8 & 9.

Run 3/8 inch copper tube between the nearest cold water line and the WATER INLET fitting on the Generator. Locate a shut-off valve near the Generator. Connect this line to the Generator with a 3/8" compression adapter. When tightening this fitting always use two wrenches so there will be no strain on the water inlet valve.

IMPORTANT

If the Generator is mounted in a place difficult for the home owner to access, the water supply shut-off valve should be located where it can be quickly accessed in an emergency.

IMPORTANT

Do not use a saddle valve or saddle fitting for the water shut-off valve. Flush water supply line before final hookup.

WARNING

The Generator will not operate properly, unless it is mounted level with its arrows pointed up.

DIAGRAM 12

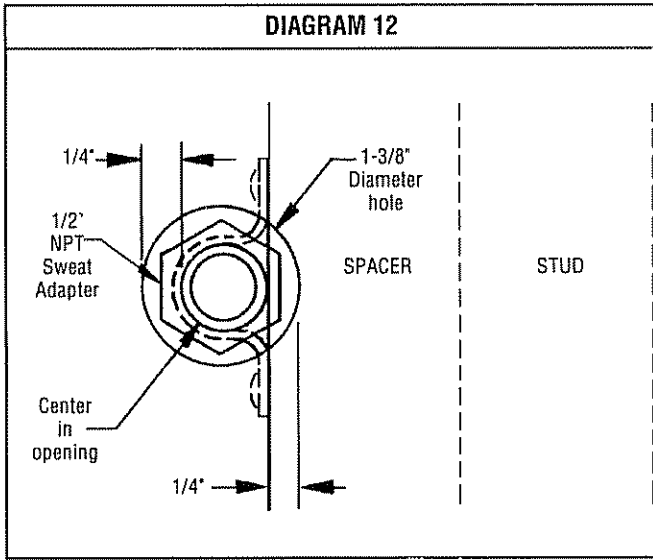

DIAGRAM 13

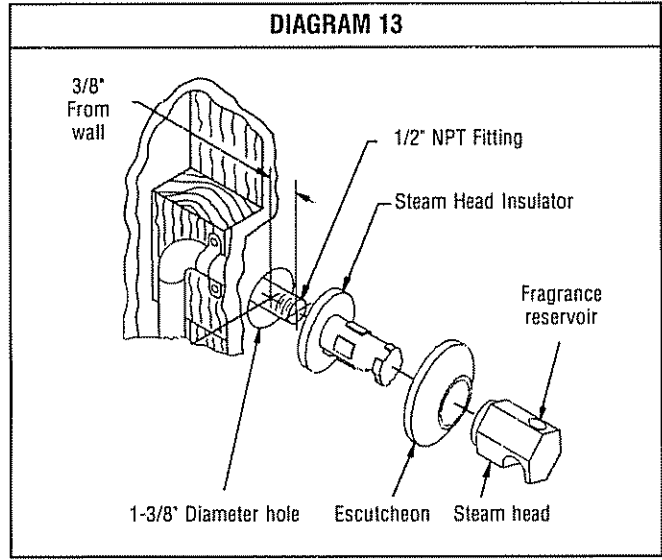

DIAGRAM 14

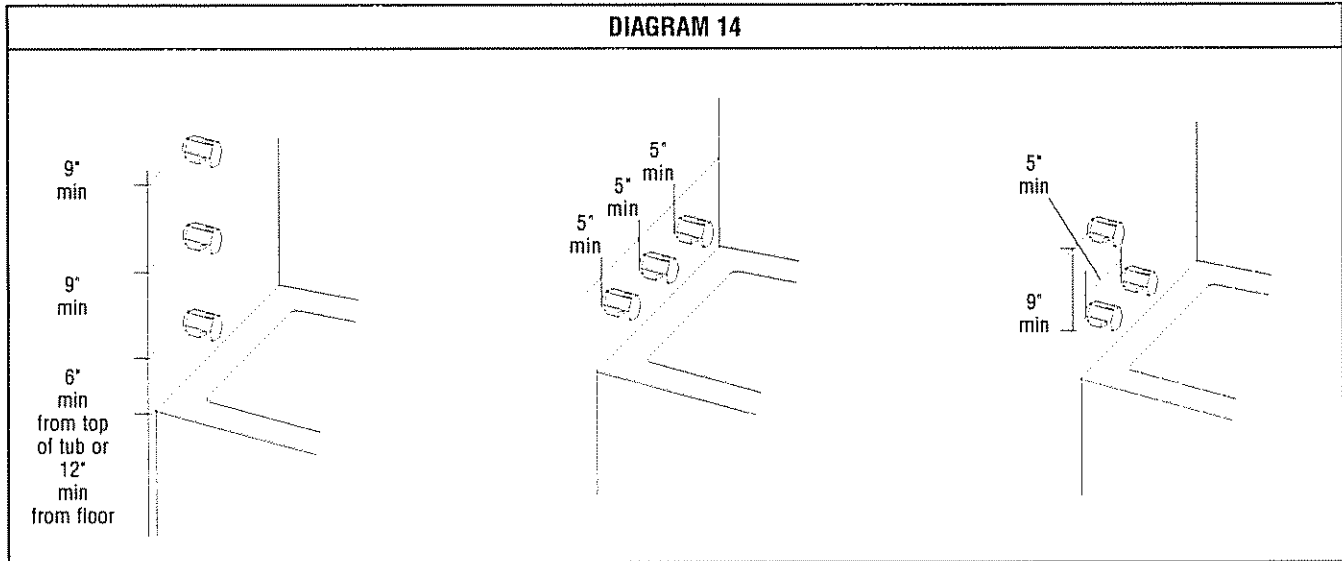

DIAGRAM 15

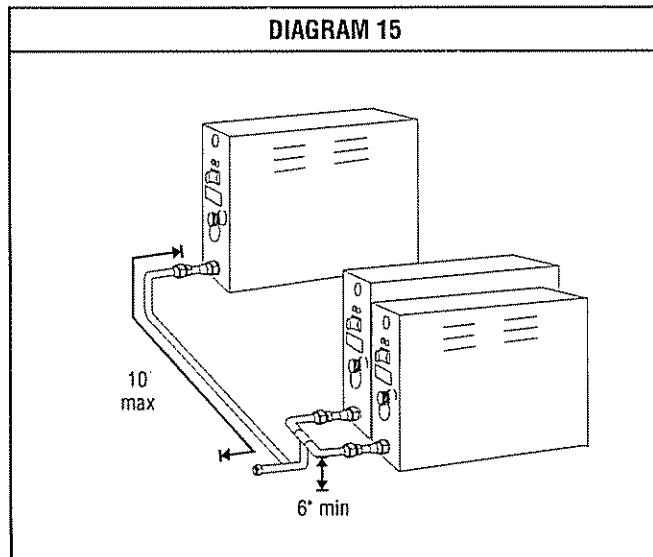
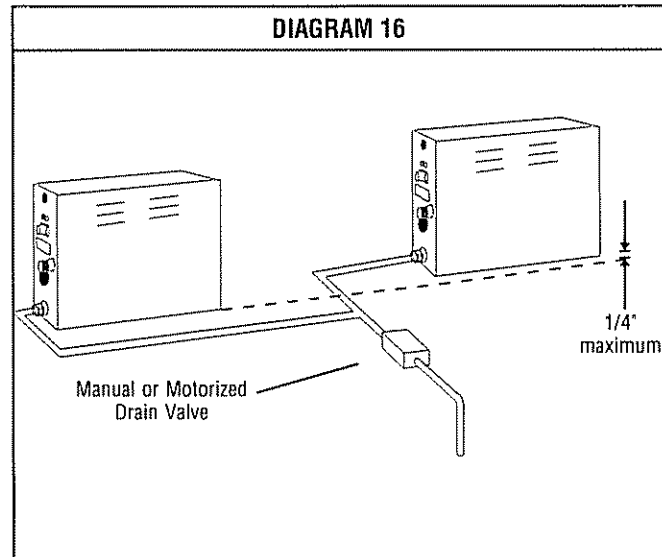

DIAGRAM 16



SECTION 5B: INSTALL STEAM LINE

SEE PREFERRED DIAGRAM 1 AND DIAGRAMS 10, 11, 12, 13 & 14.

- At the Generator:** Install a 1/2" male NPT sweat adapter. Install a 1/2" sweat union in the steam line.
 - Terminate the steam line with a 1/2" NPT male adapter. Stub the line out into the room 3/8" from the finished surface.
 - Secure the steam line to a structural member.
- Run the 1/2" copper steam line from the Generator to the Steam Room. Refer to SECTION 2: SELECT MOUNTING LOCATION.
- The steam line should enter the steam room 12" above the floor or at least 6" above a tub rim or ledge. See diagram 14.
- At the steam room:** Drill/prepare a 1-3/8" hole for the steam line entry. Center the 1/2" copper steam pipe in the 1-3/8" hole. See diagram 13.

IMPORTANT

If the steam line is in an area where the temperature will be below 40 F or if the line is more than 20 feet long, best results can be obtained by insulating the steam pipe.

SECTION 5C: INSTALL STEAM HEAD

SEE DIAGRAMS 13 & 14.

- Install steam head insulator:** Apply silicone caulk to the finished wall side of the steam head insulator and screw on hand tight until it is flush with the wall with the opening pointing down. If a hand tight fit does not align with the opening pointing down, use teflon tape on the steam line threads to adjust the fit.
- Install steam head and escutcheon:** Place the escutcheon over the steam head insulator then slide the steam head on until the escutcheon rests firmly against the finished wall. Tighten the hex head screw underneath the steam head to secure it in place with the allen wrench provided. The steam head should be level with its fragrance reservoir at the top. See diagram 13.

SECTION 5D: INSTALL PRESSURE RELIEF VALVE

Install the pressure relief valve into its port on the Generator. The pressure relief valve outlet must drain in accordance with local and national codes.

WARNING

Do not put a shut off valve in the steam line. Avoid traps and valleys where water could collect and cause a steam blockage. The hot steam line must be insulated against user contact.

To reduce the risk of explosion, do not interconnect steam outlets. A separate steam line must be provided for each steam outlet.

Centering the steam pipe is critical in rooms made of plastic, acrylic, resin, fiberglass or similar materials. Allowing the steam pipes to touch materials not rated 212° F or higher will result in damage to these materials.

Install the steam head to avoid potential user contact.

Do not install the steam head near bench(es) or where condensation will drip on the user or puddle as this puddling will present a scald hazard.

The steam pipe entry into the Steam Room and the steam head must be caulked to avoid damage caused by steam leakage into the wall.

The pressure relief valve must be installed in such a fashion that the risk of scalding is reduced to a minimum. Draining the pressure relief valve into the Steam Room may present a scald hazard.

DIAGRAM 17

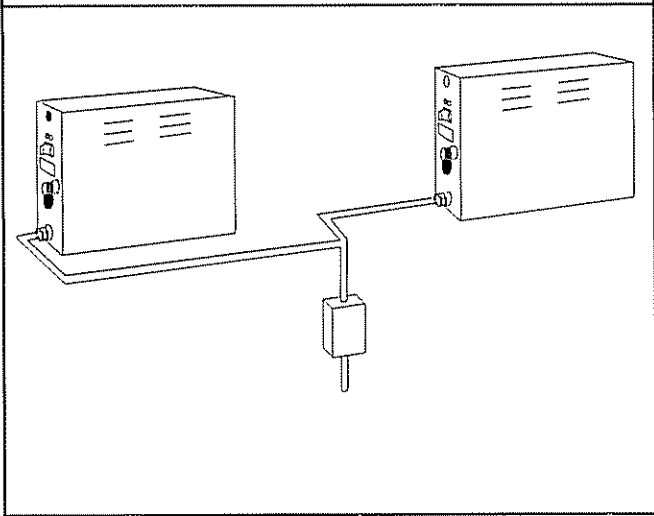

DIAGRAM 18

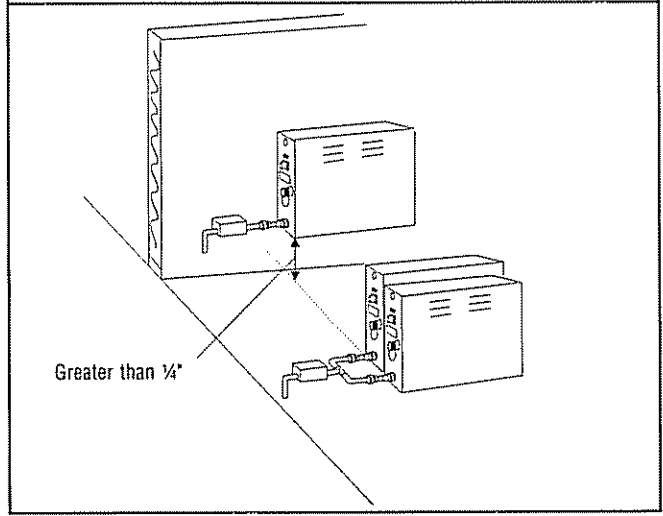

DIAGRAM 19

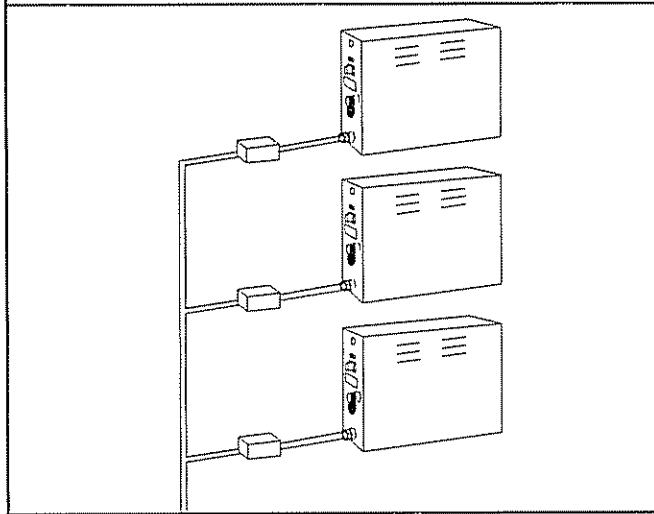

DIAGRAM 20

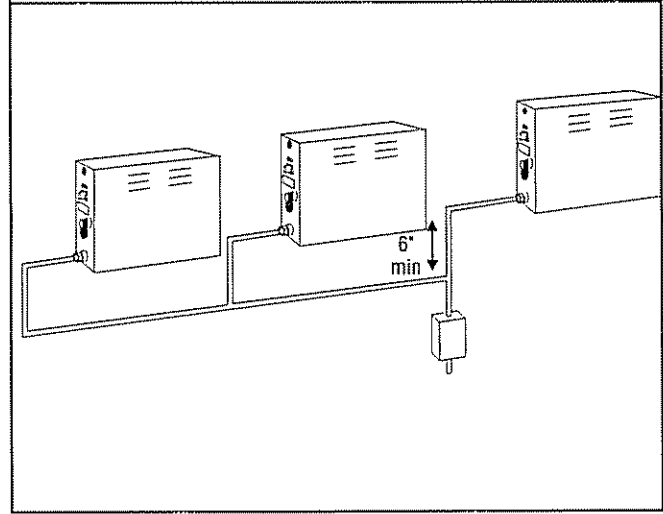

DIAGRAM 21

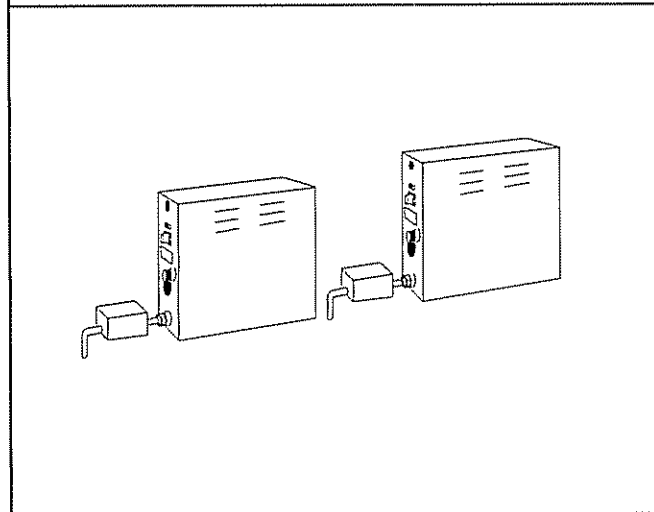
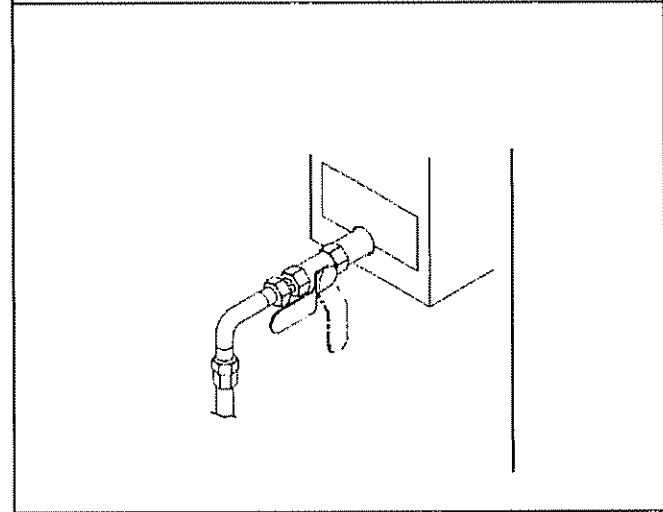

DIAGRAM 22



SECTION 5E: INSTALL DRAIN LINE(S)

SEE PREFERRED DIAGRAM 1 AND DIAGRAMS 15, 16, 17, 18, 19, 20, 21, 22 & 23.

Either Gang the drain outlets of the Master and the Slave Generators or install a separate drain line for the Slave Generator

NOTE:

The drain must be connected in accordance with local and national codes

The drain outlets of the Master and Slave Generators can be ganged together onto a single drain valve provided the following conditions can be met. See preferred Diagram 1 and Diagrams 15, 16, 17, 18, 20 & 23.

- No Generator should be more than ¼" higher or lower than any other Generator. See Diagram 16
- No Generator should have more than three (3) 90° bends (elbows or tee's), between it and the drain valve inlet. See Diagrams 15 & 20
- No Generators drain nipple should have more than ten (10) feet of pipe to the drain valve inlet. See Diagram 15
- If a motorized drain valve is being installed, it must be within three (3) feet of the Master Generator. See Diagram 23
- If ganging drains of three (3) Generators, the drain valve inlet must be at least six (6) inches below the Generator(s) outlet. See Diagram 20.

If the above conditions cannot be met, then a separate drain valve will have to be installed on the Slave Generator. See Diagrams 18, 19, 21. Then disregard the following steps and proceed to Section 5F, paragraph 2.

Ganging an existing Master to New Slave(s) At the Master Generator remove the drain valve. If this valve is motorized do the following:

- Remove the strain relief which is retaining the drain wires to the Generator. See Diagram 23.
- Open the front cover of the Generator and free the drain wires of any tie wraps.
- Do not disconnect the drain wires. These drain wires will stretch out to a maximum of three (3) feet from the Generator.
- Install ½ inch female NPT sweat adapter to the drain nipple of each Generator.
- Install ½ inch copper union on each adapter.
- Run a ½ inch copper drain line from each union and interconnect these drain lines to a single drain line.
- Terminate this single drain line with a ½ inch male NPT sweat adapter.

Ganging all new Master and Slave(s)

- Install ½ inch female NPT sweat adapter to the drain nipple of each Generator.
- Install ½ inch copper unions on each adapter.
- Run a ½ inch copper drain line from each union and interconnect these drain lines to a single drain line.
- Terminate this single drain line with a ½ inch male NPT sweat adapter.

SECTION 5F: INSTALL DRAIN VALVE

SEE DIAGRAMS 22 & 23

1 If the drain outlets have been ganged together, then install a drain valve. See Diagram 23.

2 If the drain outlets are not ganged follow 'a' or 'b' below

a If the Master Generator is equipped with a motorized valve, then an ADS Slave Drain Option Kit must be installed in this Slave Generator. Call AMEREC Service Department at 1-800-331-0349 if an ADS has not been provided.

b If the Master Generator is equipped with a manual valve, then install the provided manual valve onto this Slave Generator. See Diagram 22.

Attach the ball valve to the nipple of the drain outlet. Install a ½" union. Run a ½" copper drain line to a gravity flow drain. Do not run the drain uphill. The drain must be connected in accordance with local and national codes.

WARNING

Boiling water may be discharged from the drain. Use materials rated for boiling water.

Draining the tank into the Steam Room may present a scald hazard and /or damage materials used to construct the Steam Room.

Electrical shock hazard. Disconnect all electrical power before servicing.

Boiling water may be discharged from the drain. Use materials rated for boiling water.

Draining the tank into the Steam Room may present a scald hazard and /or damage materials used to construct the Steam Room.

DIAGRAM 23

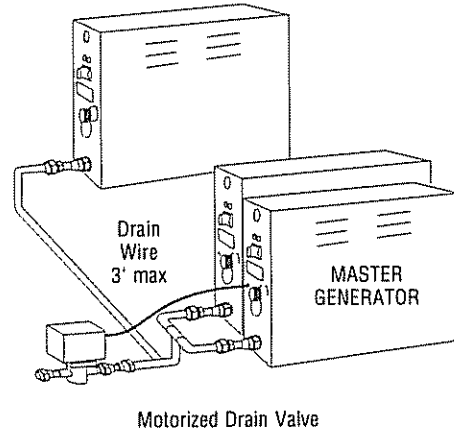
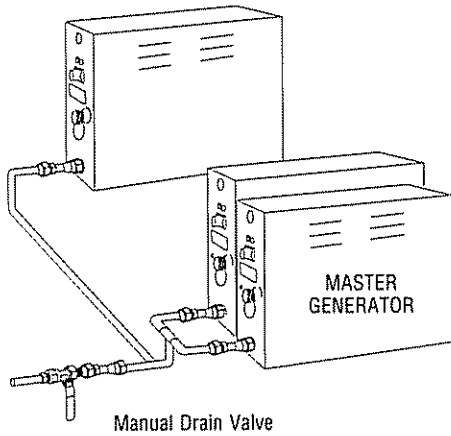

DIAGRAM 24 (K30 & K60 Controls)

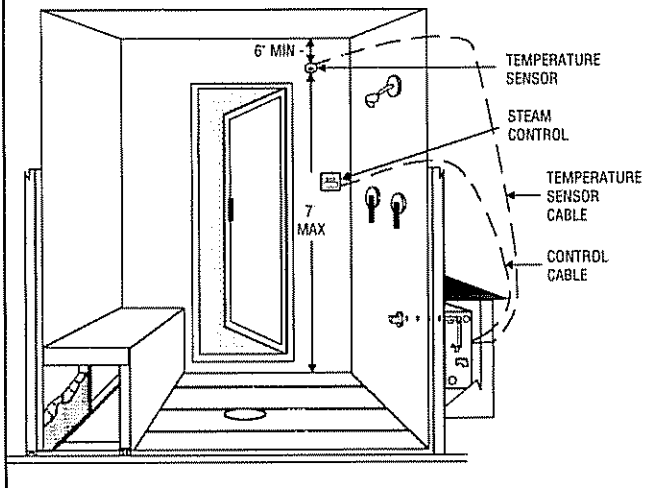

DIAGRAM 25 (K30 & K60 Controls)

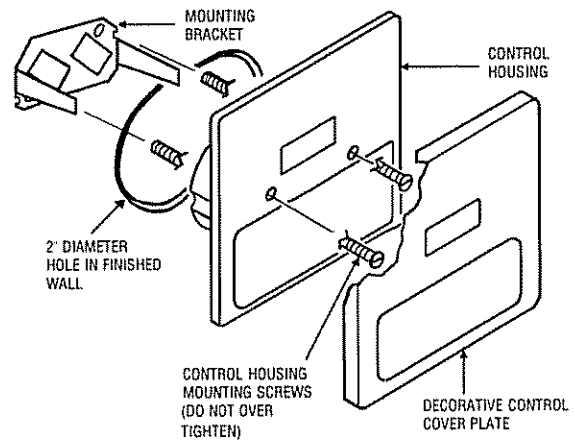

DIAGRAM 26 (K30 & K60 Controls)

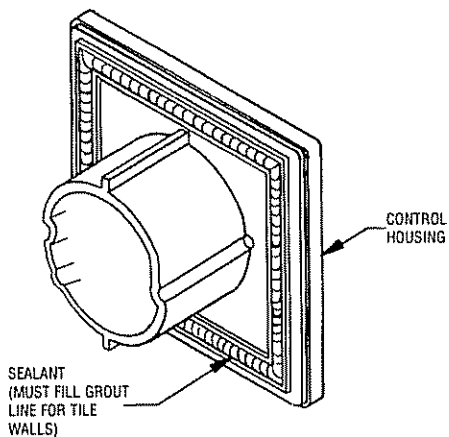
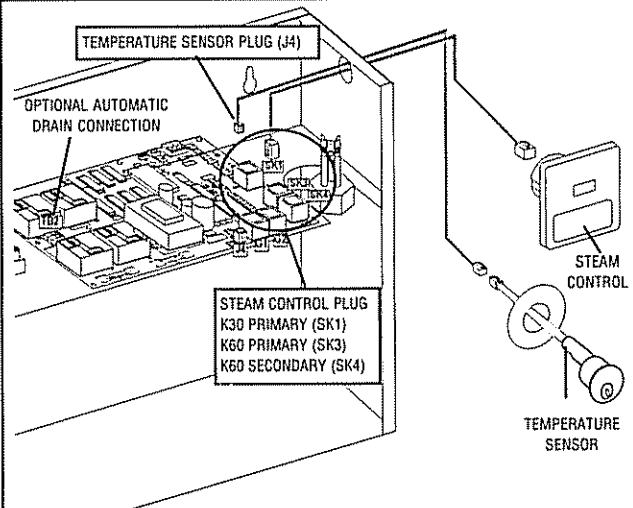

DIAGRAM 27 (K30 & K60 Controls)



SECTION 6A: WIRING INSTRUCTIONS (AM or 3M GEN. w/K60 or K30)SEE ELEC. INFO. CHART ON PG. 14 & DIA. 24, 25, 26 & 27 ON PG. 10,
& 32, 33, 34, & 35 ON PG. 24 WIRING DIA. ON PG. 14**1. CONTROL CABLE ROUGH-IN**

The low voltage control can be mounted up to 25 feet from the generator either inside or outside the steam room, also see #6 optional secondary generator control. String the 25' cable from the control location through 1/2" holes in the wall studs or ceiling joists to the generator. Note: Do not staple through or damage cable. Use factory supplied cables only. Optional for tile rooms, a 1 gang rough-in box may be installed at the desired control mounting location. A mounting plate with proper 2" diameter hole is included with the control kit. Tile up to the 2" hole in mounting plate as indicated in diagram 34

2. TEMPERATURE SENSOR CABLE ROUGH-IN

It is recommended that the sensor be mounted in the steam room 6" from the ceiling, but not directly over the steam dispersion head or more than 7 feet above the floor. String the sensor cable from the sensor location through 1/2" holes in the wall studs or ceiling joists to the generator location. Leave 12" of slack at the sensor location. Note: Do not staple through or damage cable. Use factory supplied cables only.

3. ELECTRICAL ROUGH-IN

Size wire for the generator as indicated by the Electrical Information Chart. Use correct size and type to meet electrical codes. Leave 4 feet of slack wire at generator location for finish hookup. Connect the generator to a dedicated circuit breaker. A GFI device is not required by UL. One may be installed if required by local codes or the owner. A GFI device will tend to nuisance trip due to heater element aging.

4. ELECTRICAL FINISH

Materials (locally available):
- 3/4" Strain relief for supply wire

- A. Route the copper supply wire with appropriate strain relief through the hole marked POWER ENTRY
- B. Connect the supply wires to the terminal block marked L1 and L2.
- C. Connect the ground to the ground lug (green screw on junction compartment wall).

5. INSTALL GENERATOR CONTROL

The low voltage control can be mounted directly to a finished wall either inside or outside the steam room. Using a 2" hole saw, drill a hole in the finished wall where the control is to be mounted (the control cable should already be roughed-in to this location). Locate the control cable, pull it out through the 2" hole and plug it into the connector on the back of the control housing. With the decorative cover removed, screw the two 3" control housing mounting screws 1/4" into the mounting bracket. See diagram 25. Run a

bead of 100% silicon caulk in-between the 2 ridges around the perimeter on the back of the control housing. See diagram 26. Insert the mounting bracket into the wall cavity by first pushing with the control housing and then with a hard flat surface on the control housing mounting screws which extend out through the control face. Once the mounting bracket has been inserted into the finished wall, center the control and tighten the mounting screws to draw the control housing securely against the finished wall. Do not over tighten the mounting screws. Install the decorative cover plate by sliding the top of the cover plate over the tab on the top of the control housing and pushing on the bottom of the cover plate to complete the snap fit. See diagram 32. Route the generator end of the control cable through the generator hole marked CONTROL WIRING ENTRY using the strain relief provided. Plug the control cable into the connector on the printed circuit board assembly. Insert cable into connector SK1 if a K30 control is used or connector SK3 if a K60 control is used. See diagram 27.

6. OPTIONAL SECONDARY GENERATOR CONTROL

As an option, a second K60 control can be installed with an AK generator to provide ON/OFF control both inside and outside the steam room. The second control should be installed as described in paragraphs 1 & 5, with the second control cable plugged into connector SK4 for the K60 Control on the printed circuit board assembly. See diagram 27.

7. INSTALL TEMPERATURE SENSOR

The temperature sensor should be mounted 6" below the ceiling, inside the steam room, but not directly over the steam dispersion head or more than 7 feet above the floor. Using a 7/8" hole saw, drill a hole in the finished wall where the sensor is to be mounted (the sensor cable should already be roughed-in to this location). Locate the sensor cable, pull it out through the hole and plug it into the temperature sensor. It is best to tape the sensor and cable connection together to avoid disconnection inside the wall. Apply silicon caulk as shown in diagram 33 and insert the sensor in the hole. An optional trim ring is included with the sensor. If the 7/8" hole is jagged or is cut too large the trim ring may be used to cover the exposed edges. See diagram 33. Make sure that the sensor probe is pointing down once installed. Tape the sensor in place while the silicone hardens. Route the generator end of the sensor cable through the generator hole marked CONTROL WIRING ENTRY using the control cable strain relief. Plug the sensor cable into the connector marked J4 on the printed circuit board assembly. See diagram 27.

WARNING

DIAGRAM 28 (R30i Control)

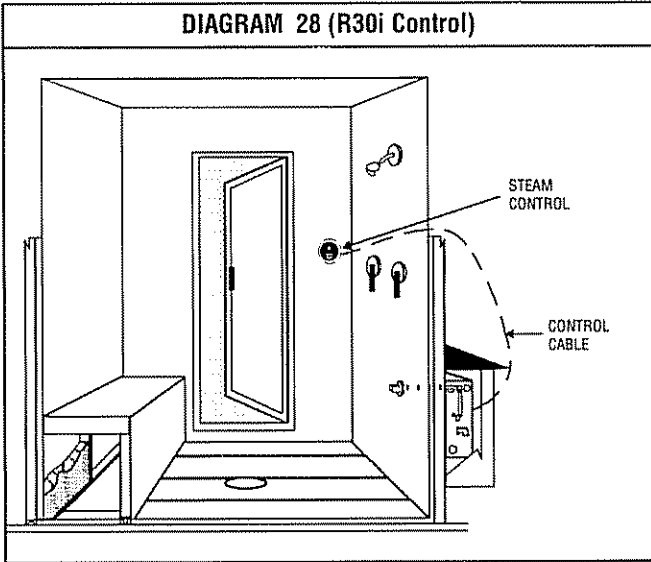

DIAGRAM 29 (R30i Control)

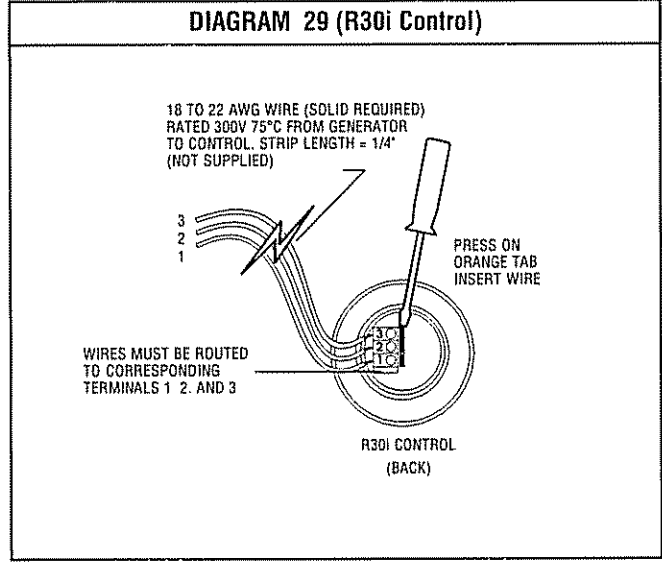

DIAGRAM 30 (R30i Control)

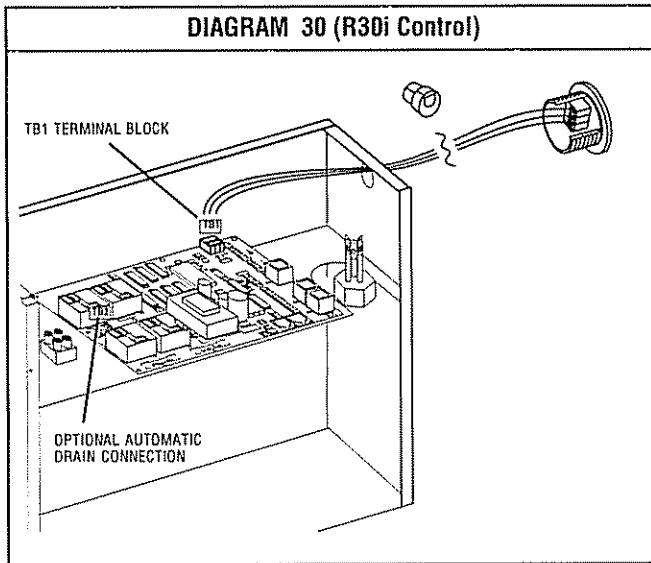
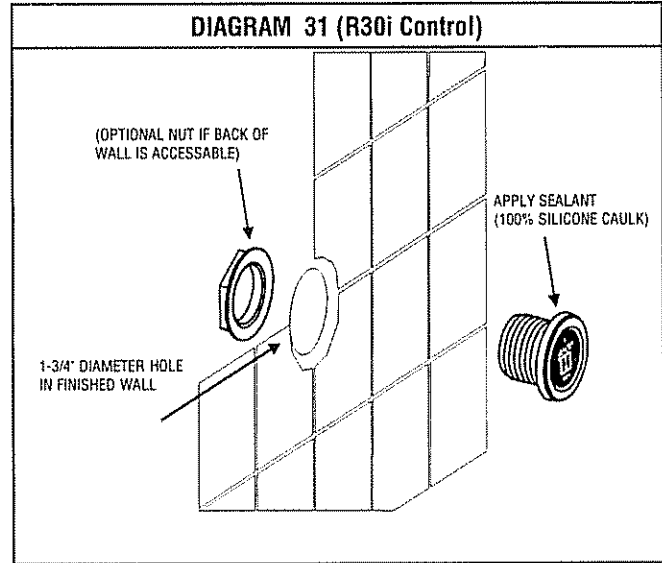

DIAGRAM 31 (R30i Control)



SECTION 6B: WIRING INSTRUCTIONS (AM or 3M GEN. w/R30i)

SEE ELEC. INFO. CHART ON PG. 14 & DIA. 28, 29, 30 & 31 ON PG. 12,
WIRING DIA. ON PG. 24

1. CONTROL CABLE ROUGH-IN

The low voltage control can be mounted up to 75 feet from the generator either inside or outside the steam room, also see #6 optional secondary generator control. String the (3) 18 to 22 AWG solid wires from the control location through 1/2" holes in the wall studs or ceiling joists to the generator.

Note:

- 1) Do not staple through or damage wires
- 2) Label or color code wires for proper TB1 to R30i orientation. See diagrams 29 & 30.

2. CONTROL CABLE FINISH

Route control wires through the generator CONTROL WIRING ENTRY and appropriate strain relief. Connect (3) wires to terminal block TB1 on the printed circuit assembly as shown in diagram 30.

3. ELECTRICAL ROUGH-IN

Size wire for the generator as indicated by the Electrical Information Chart. Use correct size and type to meet electrical codes. Leave 4 feet of slack wire at generator location for finish hookup. Connect the generator to a dedicated circuit breaker. A GFI device is not required by UL. One may be installed if required by local codes or the owner. A GFI device will tend to nuisance trip due to heater element aging.

4. ELECTRICAL FINISH

Materials (locally available):

- 3/4" Strain relief for supply wire

A. Route the copper supply wire with appropriate strain relief through the hole marked POWER ENTRY.

B. Connect the supply wires to the terminal block marked L1 and L2.

C. Connect the ground to the ground lug (green screw on junction compartment wall).

5. INSTALL GENERATOR CONTROL (R30i):

The low voltage control can be mounted directly to a finished wall either inside or outside the steam room. Using a 1-3/4" hole saw, drill a hole in the finished wall where the control is to be mounted (the control wires should already be roughed-in to this location). Locate the control wires, pull them out through the 1-3/4" hole and plug the 3 wires into the connector on the back of the control housing, as shown in diagram 29. Run a bead of 100% silicone caulk around the perimeter on the back of the control housing. See diagram 31. Insert the control into the wall cavity.

6. OPTIONAL SECONDARY GENERATOR CONTROL:

As an option, a second R30i control can be installed with an AR generator to provide ON/OFF control both inside and outside the steam room. The second control should be installed as described in paragraphs 2 & 4, with the second control wire plugged into the same connector TB1 connector as the first R30i control.

WARNING

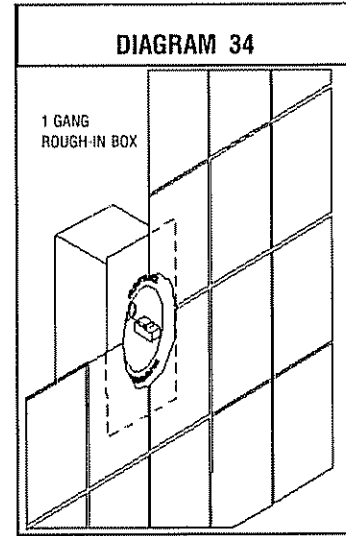
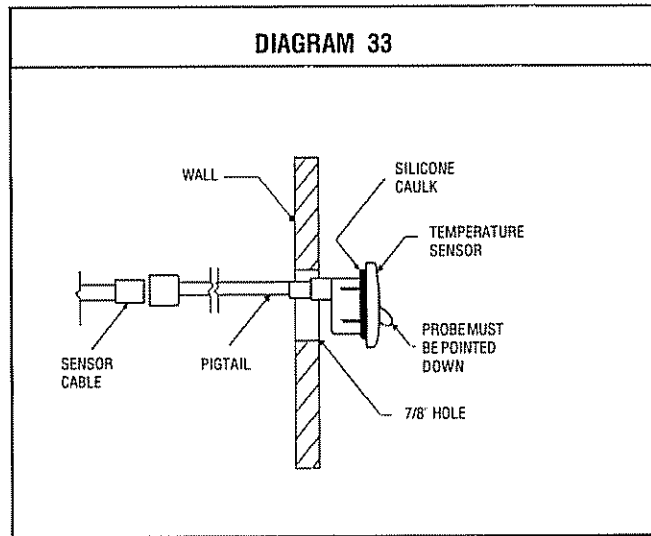
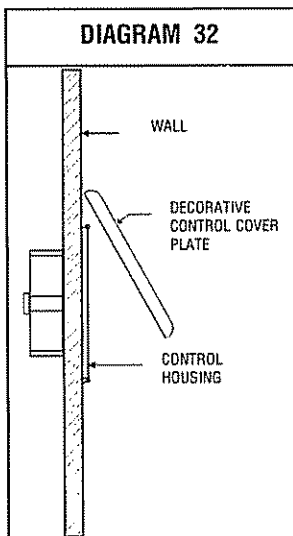

ELECTRICAL INFORMATION CHART

STEAM GENERATOR MODEL NO.	AM 10	AG 7	AG 10	3M 12	3M 14	3G 8	3G 12	3G 14
AC VOLTAGE	208 / 240	208 / 240	208/240	208	208	208	208	208
PHASE	1	1	1	3	3	3	3	3
NOMINAL WATTAGE @ 208 @ 240	7500 10000	5250 7000	7500 10000	12000 N/A	14000 N/A	8000 N/A	12000 N/A	14000 N/A
NOMINAL AMPERAGE @ 208 @ 240	36.1 41.5	25.3 29.0	36.1 41.5	33.3 N/A	40.1 N/A	21.9 N/A	33.3 N/A	40.1 N/A
UL RECOMMENDED PROTECTIVE DEVICE @ 208 @ 240	50 60	35 40	50 60	50 N/A	60 N/A	30 N/A	50 N/A	60 N/A
RECOMMENDED MINIMUM COPPER SUPPLY WIRE*	6-2 W/G	8-2 W/G	6-2 W/G	6-3 W/G	6-3 W/G	10-3 W/G	6-3 W/G	6-3 W/G

*Observe wire sizes for 208 VAC installations. 208 VAC wired units must be supplied with a minimum of 195 VAC while operating (heating). Unit is rated for copper wire only. All wire is UL approved 300V 75° deg., minimum unless otherwise specified.

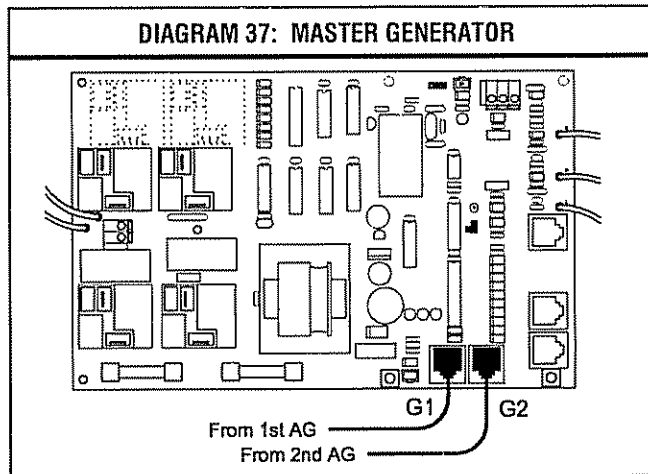
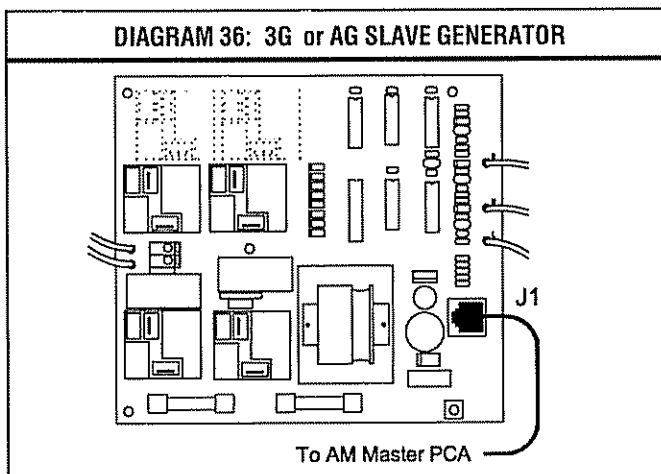

SECTION 6C: WIRING INSTRUCTIONS (AG GENERATORS)

SEE ELEC. INFO. CHART, DIAGRAMS 24, 25 AND THE WIRING DIAGRAM ON PAGE 24

1. ELECTRICAL ROUGH-IN

Size wire for the Generator as indicated by the Electrical Information Chart on page 14 Use correct size and type to meet electrical codes Leave 4 feet of slack wire at Generator location for finish hookup Connect the Generator to a dedicated circuit breaker. A GFCI device is not required by UL One may be installed if required by local codes or the owner. A GFCI may nuisance trip due to heater element aging.

2. ELECTRICAL FINISH

Materials (locally available):

- 3/4" Strain relief for supply wire
- Circuit breaker per Electrical Information Chart

- a. Route the copper supply wire with appropriate strain relief through the hole marked POWER ENTRY.
- b. Connect the supply wires to the terminal block marked L1 and L2

c. Connect the ground wire to the ground lug (green screw on junction compartment wall)

3. INSTALL SLAVE CONTROL CABLE

a. Route one end of the slave control cable through the Generator hole marked "Control Wiring Entry". Use the strain relief provided. Plug the slave control cable into the connector J1 on the AG PCA See Diagram 36.

b. Connect the other end of the slave control cable to the Master Generator. See Diagram 37.

WARNING

Electrical shock hazard - Disconnect all electrical power before servicing the Generator. All wiring should be installed by a licensed electrical contractor in accordance with local and national codes.

The Generator is designed for hookup with copper wire only

User Shock Hazard! Installer must maintain control wiring segregation. All control wiring must be restrained in the "Control Area" designated in Diagrams 36 & 37.

*Protect the AG cable per local codes if it is routed in:
 Areas exposed to weather;
 Chemical or hazardous atmospheres; Areas that may exceed their temperature ratings or... if routed adjacent to wires with voltage above 240V.*

SECTION 7: OPERATIONAL TEST

1. Assure power and water are on
2. Press the ON/OFF. The control should light-up
3. Allow 10 minutes for the steam to start.
4. Once the steam starts, press the ON/OFF. The steam should stop; there shouldn't be any water flow The control should not be lit-up
5. Press the ON/OFF. The control should light up.
6. Within one minute the unit should again produce steam. It should call for water once every two minutes

or more depending on its power rating It's normal for the flow of steam out the steam head to slow for up to 10 seconds each time the unit calls for water

7. The unit will shut down automatically in 30 minutes if the R30I or K30 Control is used, or up to 60 minutes if the K60 Control is used. When the time runs out the steam will stop and there should not be any water flow The control should not be lit

8. If the unit does not operate as described above, refer to SECTION 9: TROUBLESHOOTING GUIDE

THE UNIT IS NOW READY FOR OPERATION.

SECTION 8: SERVICE

SEE WIRING DIAGRAM ON PAGE 20

1. DESCRIPTION OF AMEREC AG (SLAVE) SERIES GENERATOR

The AG Slave is controlled by an AM Master Generator. Control signals are transmitted to the Slave from the Master via the 8 wire slave control cable provided

The AM Printed Circuit Assembly provides the interface circuitry between the AM Master and the AG Printed Circuit Assembly The AG PCA provides the basic functions necessary to produce steam. It controls makeup water, provides a water level permissive for powering the elements and provides raw DC power for the system.

2. MAINTENANCE OF AM OR AG SERIES STEAM GENERATOR

VISUAL INSPECTION - Whenever the Generator is opened inspect for any evidence of water leaks Inspect the wiring for any evidence of overheating. Check all electrical connections for tightness

FLUSH TANK - Flush monthly, or more often, depending on local water conditions

FLUSHING PROCEDURE:

- a. The Generator should be cool;
- b. Turn to Section 8: SERVICE in the Installation and Service Instructions of your Master Generator and follow that flushing procedure. The Slave Generator will mimic the Master Generator;
- c. If multiple automatic drain valves are installed, check that all the drain valve(s) are opening and closing together

DIAGRAM 38

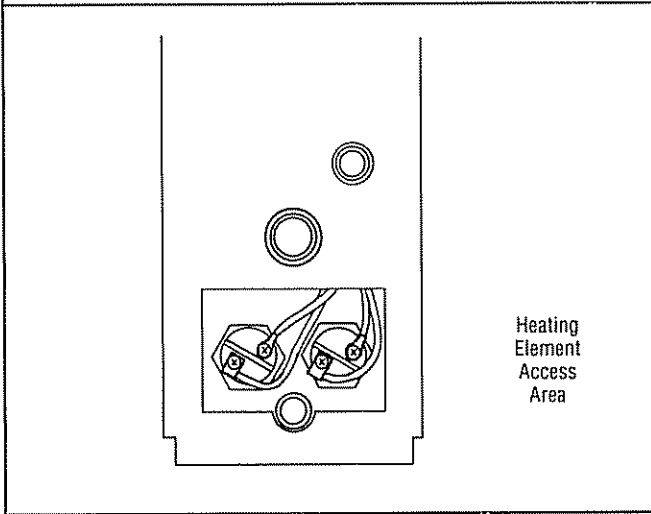

DIAGRAM 39

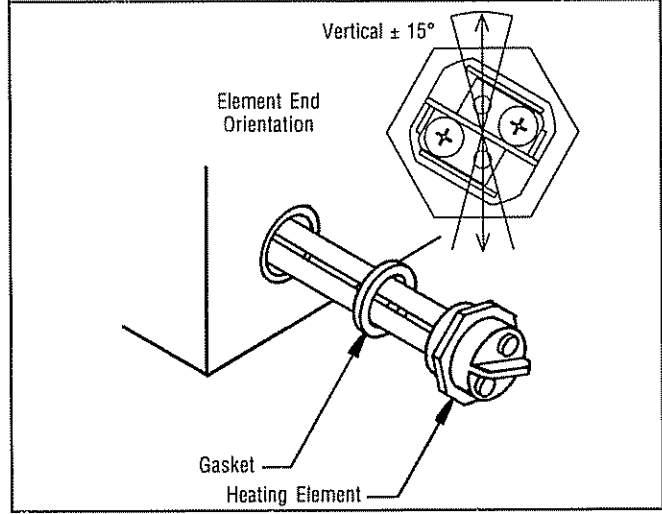

DIAGRAM 40

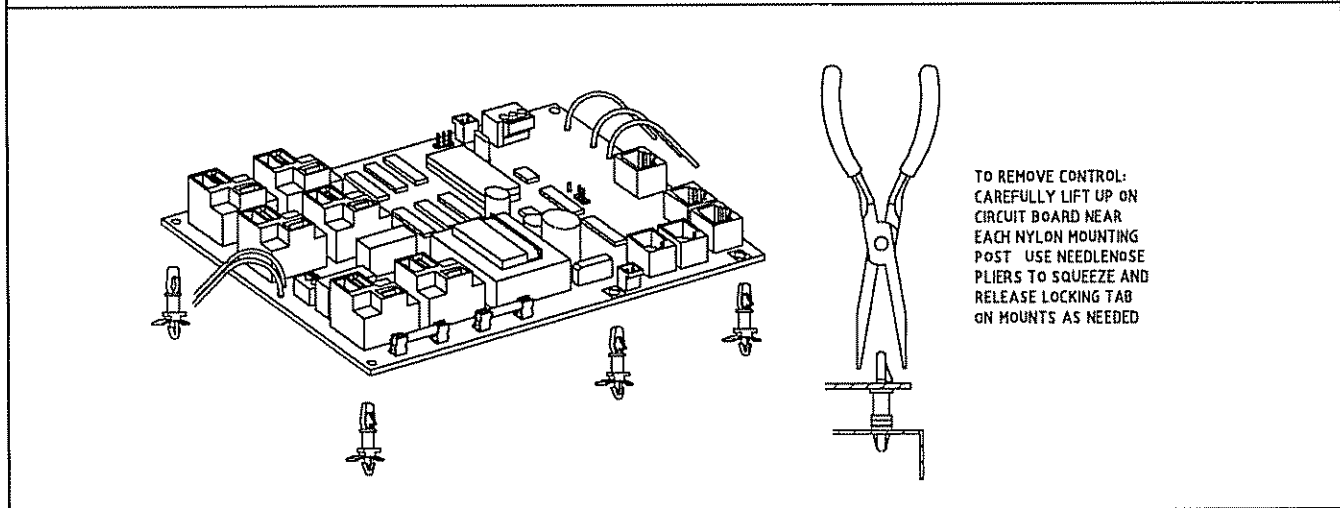

DIAGRAM 41

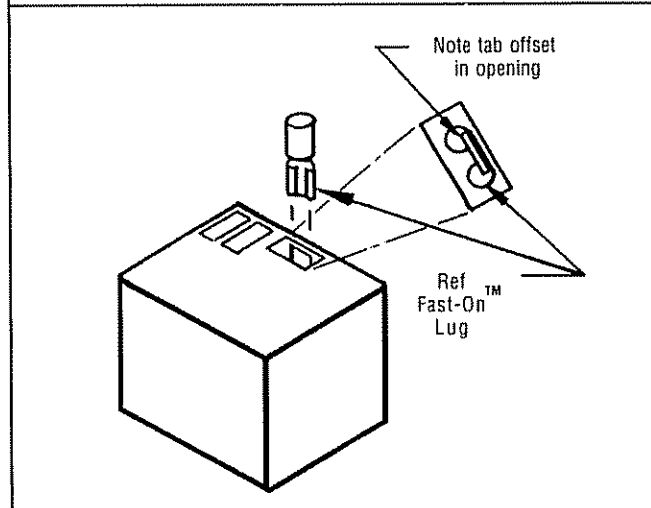
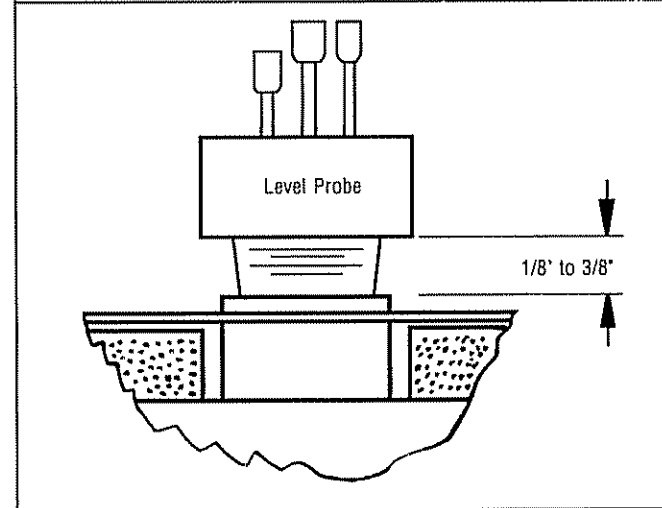

DIAGRAM 42



SECTION 8: SERVICE (continued)

SEE DIAGRAMS 38, 39, 40, 41 & 42.

3. REPAIR OF AM OR AG SERIES GENERATORS**a. ELEMENT REPLACEMENT**

Disconnect power from the unit. Drain the tank. Open the front and HEATING ELEMENT ACCESS covers. Note the wire connections. See Diagram 38. Remove the element wires. Using a hot water element socket, remove the element. To install a new element, mount a new element gasket on the element. Clean the element port and add a light coat of Rectorseal No. 5 pipe thread compound to the threads. Insert and hand tighten the element-gasket combination. Notice the element end orientation as shown in Diagram 39. Tighten the element until the orientation is the same as Diagram 39, $\pm 15^\circ$. The gasket should be set and tight but not deformed to a rounded or bulbous appearance. If the drain valve was removed, reinstall it. Reconnect the wiring. Test the unit per SECTION 7: OPERATIONAL TEST. Check for leaks at the element. Replace the front cover and the HEATING ELEMENT ACCESS cover.

b. PRINTED CIRCUIT REPLACEMENT

Printed circuit assembly (PCA) removal and replacement must be performed in the sequence described below. Any other method can damage the PCA's.

IMPORTANT

The PCA's contain static sensitive devices. Static electricity may damage PCA's. Handle accordingly.

To remove the PCA: Disconnect power from the unit. Note and tag the positions of all wires that plug into the printed circuit assembly mounted relays. Remove all the wires from the relays. When removing these wires, pull on the connector, not the wire. Disconnect all three (3) wires from the water level probe. Next slide these wires out by slightly bending the wire clamp retaining these wires. Disconnect the two (2) blue wires from the water solenoid valve. Five (5) or seven (7) stand offs hold the board in place. Remove all the stand offs by pinching the tops. When it is completely disconnected, it may be lifted out of the enclosure. See Diagram 40. To install the board, reverse this procedure. Test the unit per SECTION 7: OPERATIONAL TEST.

IMPORTANT

The blue wire connected to "L" and "P3" on the PCA must be connected to the shortest of the

three level probes.

c. WATER SOLENOID REPLACEMENT:

Disconnect power from the unit. Turn the water supply OFF. Disconnect the water supply from the water solenoid valve. Remove the front cover. Remove the two blue wires from the water solenoid valve. Rotate the self-tightening hose clamp so it can be loosened with a pair of pliers. Squeeze the clamp and move it down towards the shelf and off the valve outlet tube. Remove the two 1/4" - 20 hex head bolts and lock washers that attach the valve to the chassis. Pull the valve off the rubber fill hose. To install the valve, reverse these instructions. Test the unit per SECTION 7: OPERATIONAL TEST.

d. LEVEL PROBE REPLACEMENT:

Disconnect power from the unit. Remove the front cover. Disconnect all three (3) wires from the water level probe. Using a 1-1/4" box wrench, remove the level probe. Install a new level probe. Tighten until the bottom of the plastic nut is 1/8" to 3/8" inch above the top of the port. See Diagram 42. Reattach the three (3) wires. Test the unit per SECTION 7: OPERATIONAL TEST.

IMPORTANT

The blue wire connected to "L" and "P3" on the PCA must be connected to the shortest of the three level probes.

IMPORTANT

The level probe may be extremely tight. Damage to the insulation or chassis may result unless the tank is properly blocked or supported during probe removal or installation. It may be necessary to completely disconnect and disassemble the Generator.

WARNING

All electrical supplies should be disconnected before servicing Generator.

For continued safe operation use factory authorized replacement elements only.

Electrical Shock Hazard. PCA's have exposed 208/240 VAC on them. Disconnect 208/240 VAC power to the generator before servicing.

The relays may be damaged if the correct orientation of the connectors is not observed. See Diagram 41.

SECTION 9: TROUBLESHOOTING GUIDE

There are no user serviceable parts in the Generator. All repair should be performed by a qualified service person. For additional assistance or the factory authorized service person nearest you call, AMEREC Service Department at 1-800-331-0349. The Troubleshooting Guide below is meant as a general aid only. Follow ACTION TO BE TAKEN in order until the problem is resolved. Where replacements or repairs are indicated, see the appropriate paragraph of SECTION: 8 SERVICE.

TABLE I		
SYMPTOMS	PROBABLE CAUSES	ACTION TO BE TAKEN
Master and all Slave(s) are inoperable	Improper or no power supplied or No water supplied or AM Master PCA unit is faulty	1 Make sure circuit breakers to all Units are "On" 2 Check for proper water supply to all units 3 Check for Drain Valve(s) closed 4 Go to the Troubleshooting Guide in the Service and Installation Instructions of your Master Generator and follow that guide for further troubleshooting
Master unit is inoperable Slave unit(s) are OK	AM Master PCA unit is faulty	Go to the Troubleshooting Guide in the Installation and Service Instructions of your Master Generator and follow that guide for further troubleshooting
Master unit is OK The only Slave unit is inoperable	AM Master PCA unit faulty or Slave control cable is faulty or Slave unit is faulty	1 Make sure the Slave control cable is connected 2 In the Master unit move the Slave control cable to the unused connector on the AM PCA 3 a. If symptoms disappear replace the AM PCA. If problem remains call AMEREC Service Dept. b. If symptoms remain the same, go to Table II.
Master unit is OK One of 2 Slave units is inoperable	AM Master PCA unit faulty or Slave control cable is faulty or Slave unit is faulty	1 In the Master unit swap the Slave control cables on the AM PCA 2 If the symptoms move to the other Slave unit replace the AM PCA 3 If the symptoms remain the same, swap the Slave Generator ends of the Slave control cable between the Slave units 4 If the symptoms move to the other Slave unit the Slave control cable connected to the inoperable Slave unit is faulty - replace it - 5 If the symptoms remain the same, go to Table II
Master unit is OK Both Slave units are inoperable	Slave control cables are faulty or AM Master PCA unit is faulty	1 Make sure that the Slave control cables are connected 2 Replace the AM Master PCA unit
TABLE II		
SYMPTOMS	PROBABLE CAUSES	ACTION TO BE TAKEN
Master control "OFF" Water won't shut off and runs out of the Slave unit's steam head	Water solenoid valve is stuck open or AG PCA is faulty or Slave control cable is faulty or AM Master PCA unit is faulty	1 Turn off power to the Slave Generator. If the water stops, go to step 3 2 a. Remove the water solenoid valve, disassemble, clean, re-assemble, and check for proper operation b. Replace valve. If problem remains call AMEREC Service Department. 3 a. Unplug the Slave control cable connected to the Slave unit. b. Turn ON power to the Slave unit. c. If water stops running, replace the AM PCA in the Master unit. d. If the water doesn't stop running, Call AMEREC Service Department.
Master control "ON" Water won't shut off and runs out of the Slave unit's steam head	Slave unit improperly grounded or Connection between the blue wire and the water level probe is faulty or AG PCA is faulty or Slave control cable is faulty or AM Master PCA unit is faulty	1 Check that the Slave Generator is properly grounded 2 Check the green ground wires to the Slave tank and the PCA 3 Check that the blue wire is properly attached to the water probe 4 a. Unplug the Slave control cable connected to the Slave unit. b. If water stops running, replace the AM PCA in the Master unit. c. If the water doesn't stop running, Call AMEREC Service Department.

TABLE II Con't.

SYMPTOMS	PROBABLE CAUSES	ACTION TO BE TAKEN
<p>Master Unit steams Slave unit won't steam</p>	<p>Improper or no power supplied or No water supplied or Plugged water solenoid valve or Water level probe is faulty or Burnt out heating elements or AG PCA is faulty or Slave control cable is faulty or AM PCA in the Master unit is faulty</p>	<ol style="list-style-type: none"> 1 a. Make sure the circuit breaker to the Slave unit is "ON" b. Using a voltmeter, check the voltage across the two fuses on the Slave PAL. Voltage should be 208/240V c. Check fuses on the Slave PAL. If fuse(s) are blown, replace with Buss MDL 15/100 or equivalent fuse. If the fuse blows again - call Nasscor's Service Department. 2. Check for proper water supply (supply valve "ON") to Slave unit. 3. Check for Slave (or common) drain valve closed 4 a. Push the Master unit's control "OFF" b. Open the Slave (or common) drain valve allowing tank to drain completely c. Close the drain valve d. Push the Master unit's control "ON" e. Unit will begin filling. Listen for a click noise on the Slave unit. Within 20 seconds after click noise is heard, the water fill will shut off. This will indicate the Slave tank is full. Go to step 7 if the tank does not fill - See SYMPTOMS: "Slave unit won't fill up" 5. If the Slave tank has filled but the relay click was not heard, temporarily ground the two long probes of the water level probe. If the click is heard as both the probes are grounded, check probe wiring, if ok replace the level probe. If the click is not heard go to step 6. 6. Call AMEREC Service Department.
<p>Master unit "ON" Slave tank drained Slave unit won't fill up</p>	<p>Improper or no power supplied or No water supplied or Plugged water solenoid valve or Water solenoid valve faulty or Level probe faulty or AG PCA faulty or Slave control cable faulty or AM PCA in the Master unit is faulty</p>	<ol style="list-style-type: none"> 1 a. Make sure the circuit breaker to the Slave unit is "ON" b. Using a voltmeter, check the voltage across the two fuses on the Slave PCA. Voltage should be 208/240V. c. Check fuses on the Slave PCA. If fuse(s) are blown, replace with Buss MDL 15/100 or equivalent fuse. If the fuse blows again - call AMEREC Service Department. 2. Check for proper water supply (supply valve "ON"). Check for drain valve closed 3. Remove the blue wire from the level probe. If the unit fills, clean or replace the level probe 4. Reconnect the blue wire to the shortest level probe. At the water valve solenoid, slide back the red connector enough to get the voltmeter probes on the solenoid terminals. Measure the voltage across the solenoid terminals. If it is not 208/240V, replace the PCA. If 208/240V is found, proceed with steps 5 & 6. 5. Remove water solenoid valve: disassemble, clean, reassemble and check for proper operation 6. Replace the water solenoid valve 7. Call AMEREC Service Department.
<p>Water continually sputters out of any steam head</p>	<p>Foaming containinants in the water supply</p>	<ol style="list-style-type: none"> 1. Flush tank 3 times. See Section 8: FLUSHING PROCEDURE 2. Call AMEREC Service Department.

DIAGRAM 43 (AM GENERATOR)

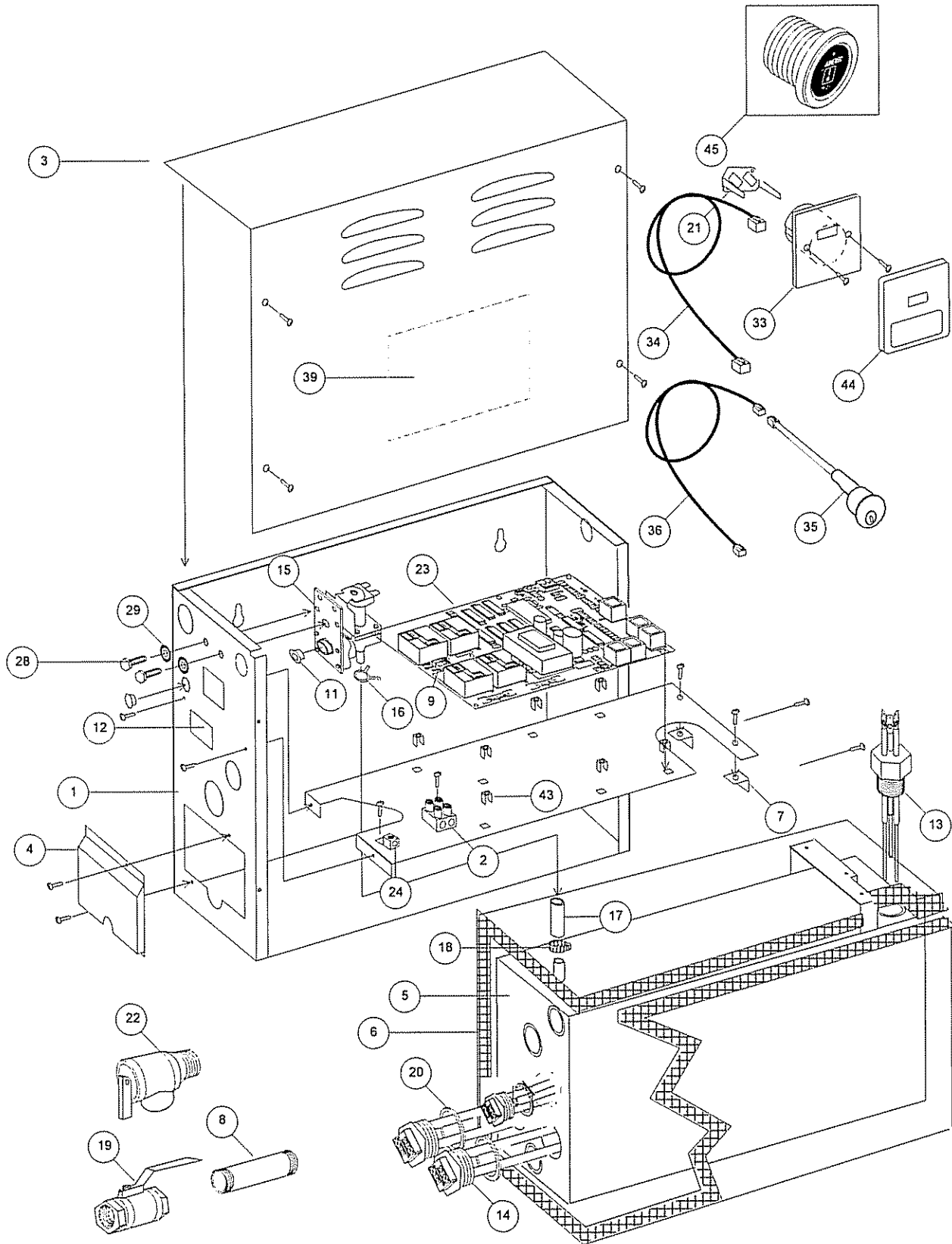

PARTS LIST (AM GENERATOR)

NUMBER	PART NAME	DESCRIPTION
1	FRAME	CHASSIS
2	TERMINAL	POWER INPUT TERMINAL BLOCK
3	COVER	FRONT WITH WD LABEL
4	COVER	ELEMENT ACCESS
5	TANK	TWO ELEMENTS
6	INSULATION	BLANKET
7	BRACKET	L BRACKET
8	NIPPLE	DRAIN NIPPLE
9	TERMINAL	OPTIONAL AUTO FLUSH TERMINAL BLOCK
11	CAP	CAP, THREAD PROTECTOR
12	LABEL	UL RATING
13	PROBE	TRIPLE LEVEL
14	ELEMENT	REPLACEABLE ELEMENT
15	VALVE	WATER INLET
16	CLAMP	SELF-TIGHTENING
17	HOSE	WATER
18	CLAMP	AUGER
19	VALVE	MANUAL DRAIN
20	GASKET	ELEMENT
21	BRACKET	MOUNTING BRACKET
22	VALVE	PRESSURE RELIEF
23	PCA	*BLACK* PRINTED CIRCUIT ASSEMBLY, 3K
24	LUG	GROUND
28	BOLT	1/4-20 x 1/2"
29	WASHER	1/4" LOCK
33	CONTROL HOUSING	CONTROL HOUSING
34	CABLE	CONTROL CABLE
35	SENSOR	TEMPERATURE SENSOR
36	CABLE	TEMPERATURE SENSOR CABLE
37	STEAM HEAD	DISPERSION HEAD (NOT SHOWN)
38	PLACARD	SAFETY (NOT SHOWN)
39	LABEL	WIRE DIAGRAM
40	FUSES	15/100 SLO-BLO (NOT SHOWN)
41	FUSES	3A SLO-BLO (NOT SHOWN)
43	STANDOFF	STAND OFF
44	COVERPLATE	DECORATIVE CONTROL COVER PLATE
45	CONTROL	R30i CONTROL

PARTS AND / OR RETURNS:

• For assistance or parts ordering, please contact your local AMEREC Dealer or AMEREC at 1-800-331-0349. Please help us to serve you better by:

1. Identifying the problem by using the troubleshooting guide in this manual.

2. Read Number 12, the UL Ratings Label, to obtain your unit's model and code number.

3. When ordering parts, please provide the number, description and quantity needed. When ordering wires or wire assemblies, please describe the wires by color, location and / or their connection points.

4. Do not return any material to AMEREC without first contacting AMEREC for a Return Authorization Number. Freight must be prepaid to AMEREC.

DIAGRAM 44 (AG GENERATOR)

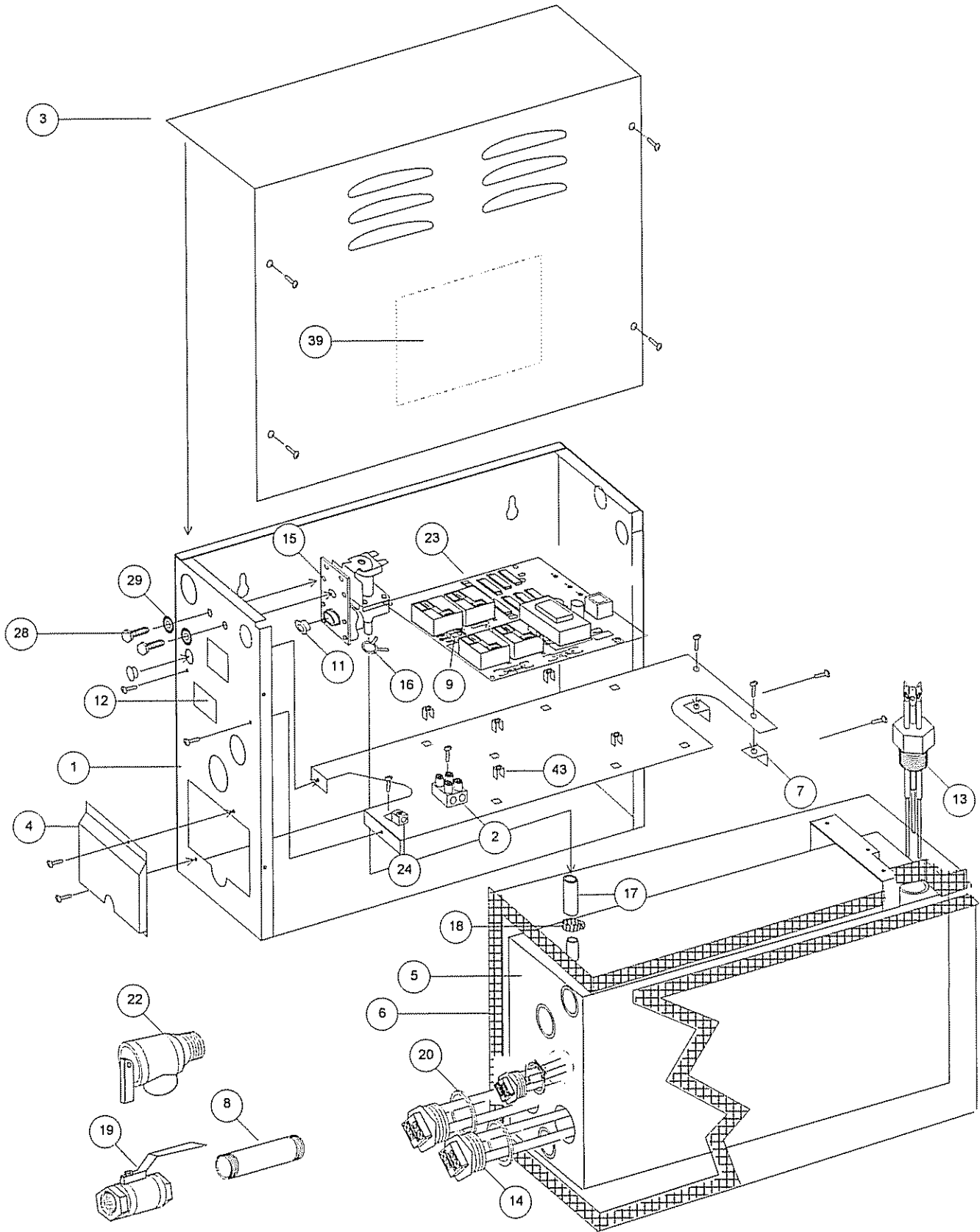

PARTS LIST (AG GENERATOR)

NUMBER	PART NAME	DESCRIPTION
1	FRAME	CHASSIS
2	TERMINAL	POWER INPUT TERMINAL BLOCK
3	COVER	FRONT WITH W/D LABEL
4	COVER	ELEMENT ACCESS
5	TANK	TWO ELEMENT
6	INSULATION	BLANKET
7	BRACKET	L BRACKET
8	NIPPLE	DRAIN NIPPLE
9	TERMINAL	OPTIONAL AUTO FLUSH TERMINAL BLOCK
11	CAP	CAP, THREAD PROTECTOR
12	LABEL	UL RATING
13	PROBE	TRIPLE LEVEL
14	ELEMENT	REPLACEABLE ELEMENT
15	VALVE	WATER INLET
16	CLAMP	SELF TIGHTENING
17	HOSE	WATER
18	CLAMP	AUGER
19	VALVE	MANUAL DRAIN
20	GASKET	ELEMENT
21	BRACKET	MOUNTING BRACKET
22	VALVE	PRESSURE RELIEF
23	PCA	"BLACK" PRINTED CIRCUIT ASSEMBLY, AG
24	LUG	GROUND
28	BOLT	1/4-20 x 1/2"
29	WASHER	1/4" LOCK
37	STEAM HEAD	STEAM DISPERSION HEAD (NOT SHOWN)
38	PLACARD	SAFETY (NOT SHOWN)
39	LABEL	WIRE DIAGRAM
40	FUSES	15/100 SLO-BLO (NOT SHOWN)
41	FUSES	3A SLO-BLO (NOT SHOWN)
43	STAND OFF	STAND OFF
44	CABLE	SLAVE CONTROL CABLE (NOT SHOWN)

PARTS AND / OR RETURNS:

• For assistance or parts ordering, please contact your local AMEREC Dealer or AMEREC at 1-800-331-0349. Please help us to serve you better by:

1. Identifying the problem by using the troubleshooting guide in this manual.

2. Read Number 12, the UL Ratings Label, to obtain your unit's model and code number.

3. When ordering parts, please provide the number, description and quantity needed. When ordering wires or wire assemblies, please describe the wires by color, location and / or their connection points.

4. Do not return any material to AMEREC without first contacting AMEREC for a Return Authorization Number. Freight must be prepaid to AMEREC.

WIRING DIAGRAM

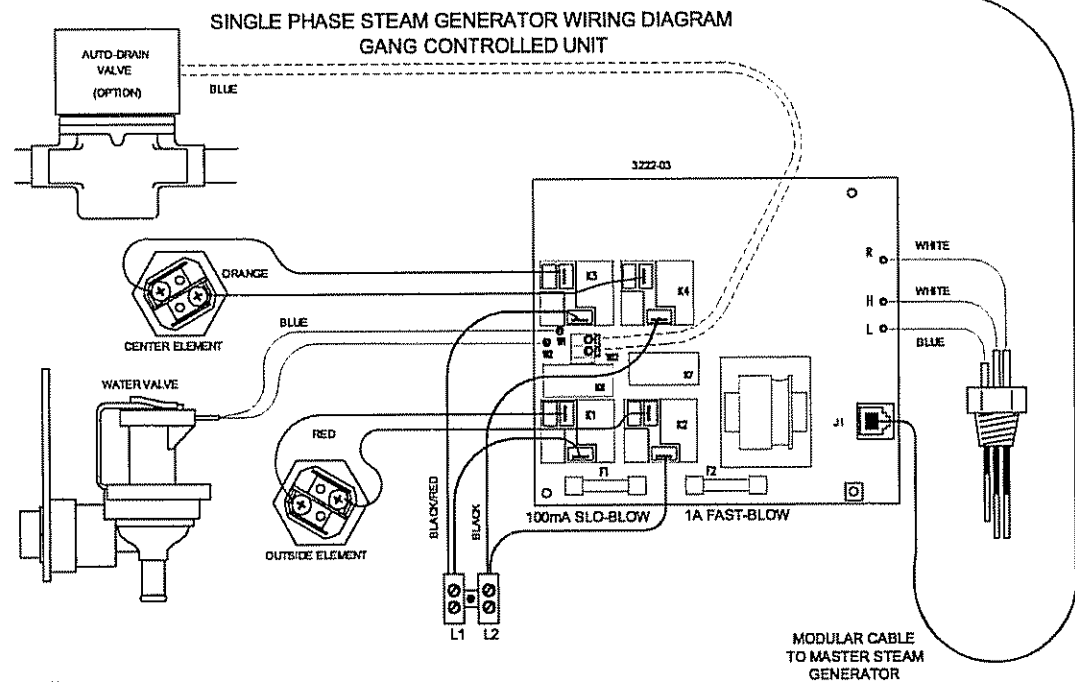
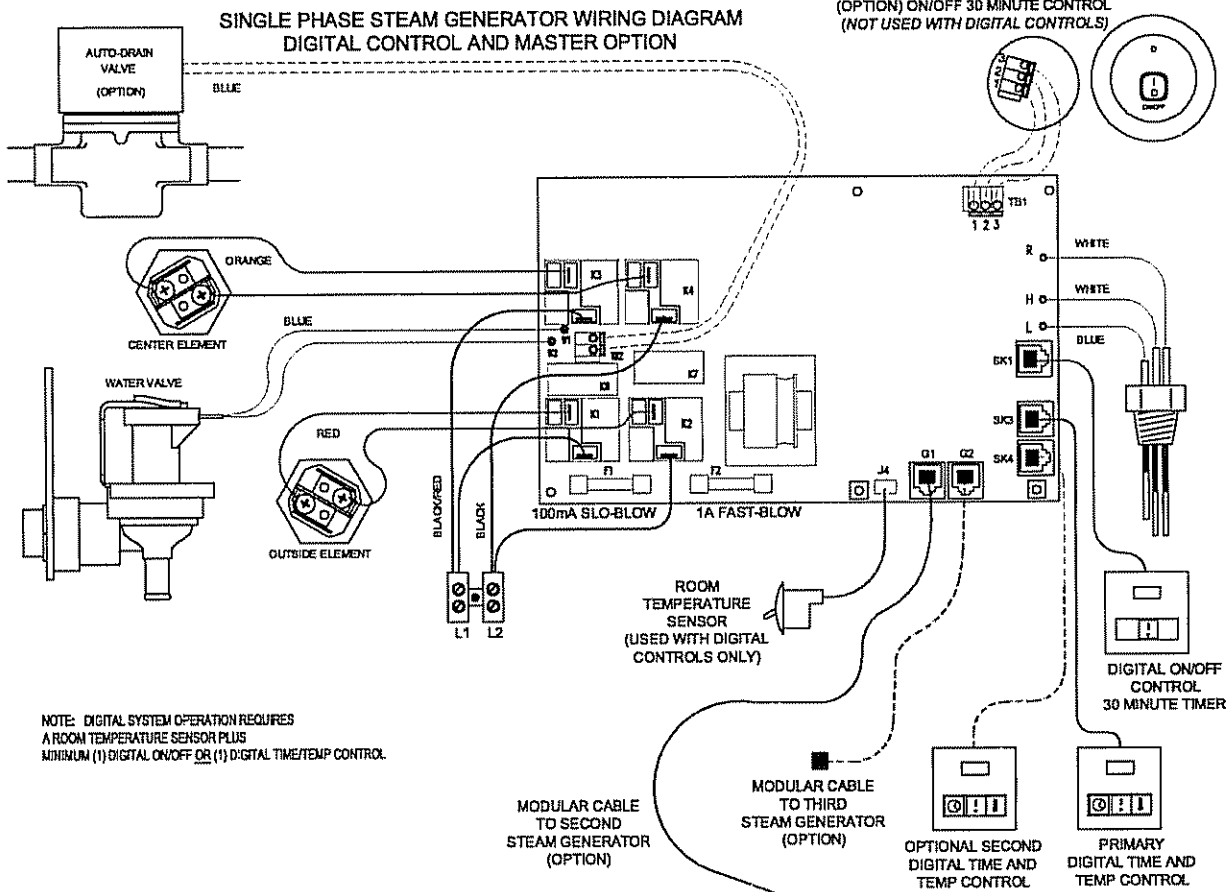

26 AUG 02

WIRING DIAGRAM

