

# STEAMIST

## HEAVY COMMERCIAL STEAMBATH GENERATOR

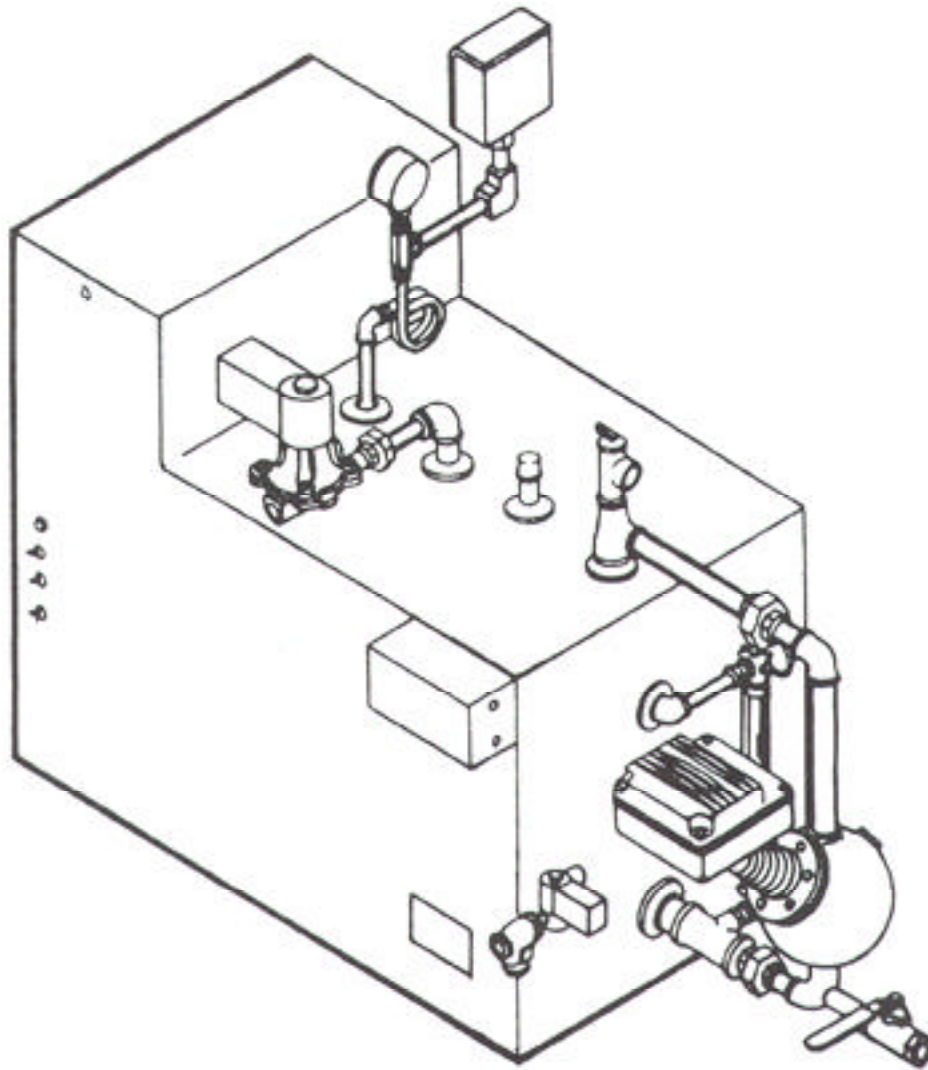

### *OWNERS MANUAL*

Models HC-24 Thru HC-72

# TABLE OF CONTENTS

Title	Page
I. Plumbing Installation.....	1
A. Plumbing Pre-Installation .....	1
B. Plumbing Rough-In .....	1
C. Steam Generator Plumbing Installation.....	2
11. Electrical Installation .....	2
A. Electrical Pre-Installation .....	2
B. Electrical Rough-In .....	2
C. Steam Generator Electrical Installation.....	2
III. CP-1 Control Package Installation and Operation .....	4
A. Pre-Construction Considerations .....	4
B. CP-1 Control Package Rough-In .....	5
C. CP-1 Control Package Installation .....	5
D. Steam Solenoid Valve .....	6
E. Operation .....	6
IV. Auto Blowdown and Automatic ON/OFF Time Clock.....	8
V. Steam Generator Operation.....	8
VI. Steam Generator Maintenance.....	8
A. Manual Blowdown .....	8
B. Periodic Inspection .....	8

# LIST OF ILLUSTRATIONS

Figure	Page
1. Dimensional Drawing for Heavy Commercial Steam generator (HC-24 thru HC-72) .....	1
2. Typical Steam generator Installation .....	3
3. ST-200C Temperature Sensor Installation .....	4
4. ST-200C Temperature Control Installation .....	5
5. System Control Module Installation .....	6
6. Installed CP-1 Control Package.....	7
7. Automatic Blowdown and Automatic ON/OFF Time Clocks.....	9
8. "HC" Wiring Diagram with Option.....	11

**IMPORTANT: Read all instructions before installing equipment**

## PLUMBING INSTALLATION

The Heavy Commercial Steam Generator (HC-24 thru HC-72) comes factory assembled, carefully wired, and tested. All work must conform to local and national codes. All power must be OFF to the steam generator when installing or servicing the unit.

**WARNING** - Elderly persons, pregnant women, or those suffering from heart disease, high blood pressure, diabetes, or not in good health must not use this device unless directed by a physician. Also, steambathing should be avoided while intoxicated.

### I. PLUMBING INSTALLATION A. Plumbing Pre-Installation

- 1) Insure that the model steam generator unit you have purchased is sized adequately for your steamroom.
- 2) Allow sufficient room (30" minimum) for access to the unit in the event service is required. Do not keep flammable materials such as gasoline, thinners, paints, etc. In the same area as the steam generator.
- 3) The steam generator must be located as close as possible to the steamroom. If the steam generator is more than ten feet from

the steamhead, Insulate the steam pipe. The serial number plate should be visible. Refer to Figure 2 for Installation drawing. Do not Install outdoors or an area where parts may freeze or corrode. Also, do not install near combustible materials, i.e., paints, thinners, chlorine, etc.

- 4) The steamroom must be completely sealed on all sides, top, and bottom. Floor, walls, and ceiling should be completely covered with waterproof material. In the event that the walls or ceiling are exposed plaster, sheetrock, or plaster board, a waterproof paint must be applied to seal the surfaces.

### B. Plumbing Rough-in

The Heavy Commercial "HC" Steam Generator requires the following connections: 1/2" NPT piping for water inlet. 3/4" NPT brass or 1" (I.D.) copper tubing for steam outlet, and 3/4" NPT safety valve should be piped to an indirect waste line. A 3/4" minimum indirect waste line must be installed for the drain. This should be completed before walls are installed.

Before connecting the water line it is important to make sure the line is thoroughly clean and free of foreign matter.

- 1) Rough-in a water line from hot (preferably) or cold water pipe; brass pipe or

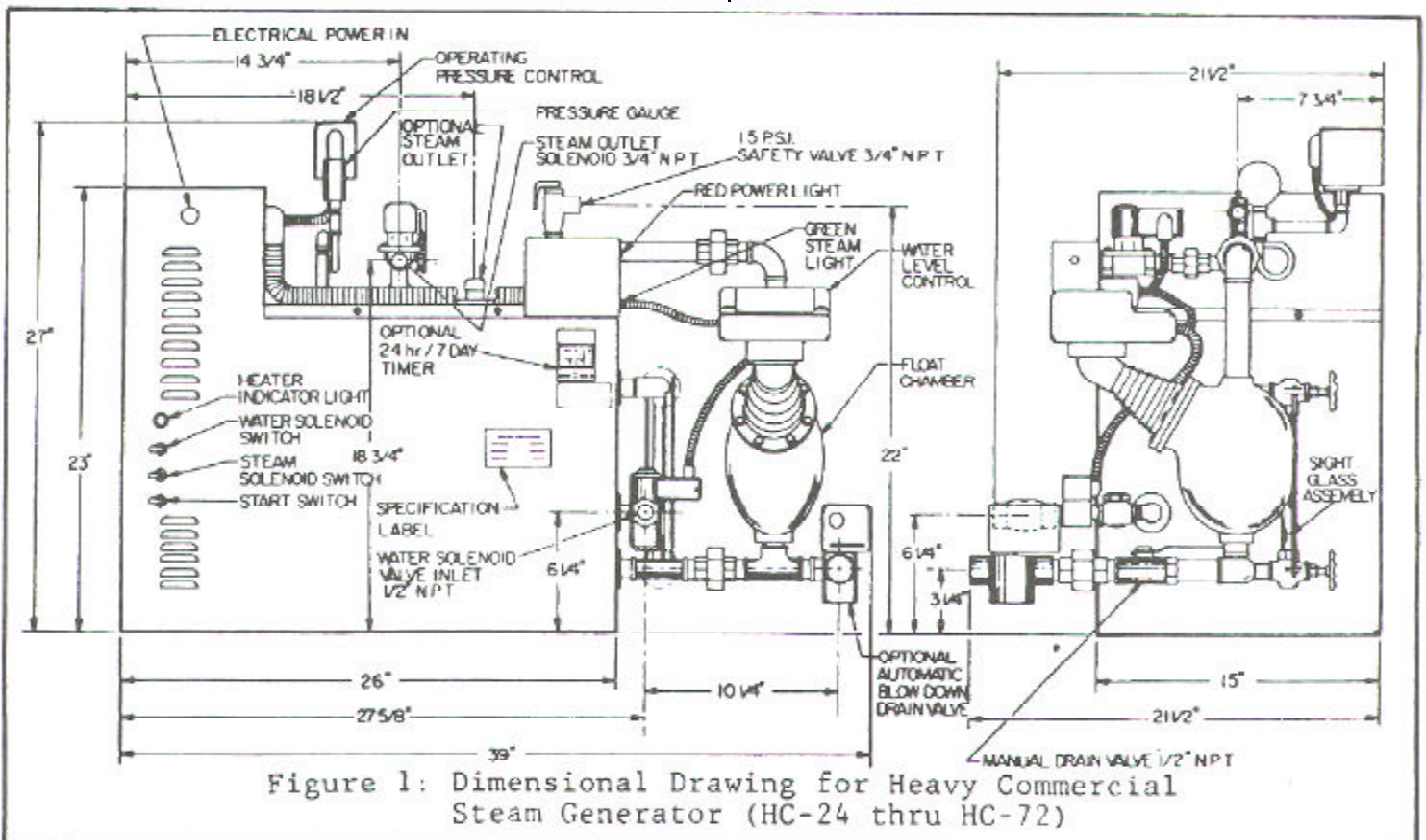

# ELECTRICAL INSTALLATION

copper tubing is recommended. A shut-off valve should be conveniently placed in the water feed line.

- 2) Rough- in the steam line using 1/2" NPT brass pipe or 1 " I. D. copper tubing. Do not use iron pipe. it will rust and discolor wall of steamroom. For a steam line that is longer than 10 feet, insulation must be used. The steamhead location should be approximately 12" to 18" above the steamroom floor.

CAUTION: NO shut-off valve should be installed on the steam line. Do not create traps or valleys in this line which would trap condensation and block the flow of steam. The steam pipe should be pitched away from the steamhead allowing condensation to run back into steam generator (Preferably) Or pitched toward the steamhead.

- 3) Rough- in a 3/4" indirect waste line to be used for the safety valve and drain. The indirect drain must be in accordance with local plumbing codes.

## C. Steam Generator Plumbing Installation

Care must be taken when installing the steam generator. Leave proper access for servicing (30" minimum each side). (Refer to Figure 2 for typical steam generator installation.)

CAUTION: The steam generator is designed to be used ONLY in an upright and level position ; to do otherwise would damage the unit and void the warranty.

- 1) If needed mount the steam generator on a platform to allow draining into a basin or into previously installed indirect waste line.

NOTE: Optional automatic blowdown must be piped into the 3/4" indirect waste line.

- 2) Connect the 3/4" NPT safety valve into the previously installed indirect waste line.
- 3) In areas where high water pressure may be a problem a water hammer arrestor should be installed. Connect the water supply to the steam generator connection marked "water inlet". (See Figure 1.)
- 4) Connect the steam line from the previously roughed-in location to the steam solenoid valve on the generator marked "steam outlet". (See Figure 1.)

- 5) In the steamroom. place the center of the escutcheon onto the steam pipe and Screw the steamhead into place. Care must be taken not to Scratch the steamhead or escutcheon with a wrench. Be Sure the steam slot in the steamhead is facing down.

After the plumbing connections are complete the electrician may finish the wiring and test the unit.

## II. ELECTRICAL INSTALLATION

### A. Electrical Pre- Installation

- 1) Determine proper size of wire, voltage, amperage, and phase for the steam generator.
- 2) Inline fuse/circuit breaker required: fu or circuit breaker sized in accordance with specification label. Do not install a (GFI) Ground Fault interrupter to this equipment.

### B. Electrical Rough-In

- 1) Route power supply cable to the location the steam generator will be installed before walls are closed.

### C. Steam Generator Electrical Installation

**WARNING ALL POWER TO THE STEAM GENERATOR MUST BE TURNED OFF.**

- 1) Locate appropriate knockout found on top of the steam generator. Mount proper strain relief into knockout hole.
- 2) Strip back the power cable's outer insulating jacket twelve inches and insert into steam generator. Strip back insulation 1/2" from the incoming wires; single phase (two power and one ground). 3 phase (three power and one ground).
- 3) Insert ground wire into grounding lug located on the lower left side wall of the gray electrical power box.

CAUTION: Insure ground wire does not come in contact with live electrical connections.

- 4) Locate the fuse block. found in the upper part of the gray power box. Insert power wires into the proper power lug terminals on top of the fuse block and secure.

## ELECTRICAL INSTALLATION

- 5) If connections are made properly the indicator lamp will illuminate when the generator is heating.

NOTE: Steam Generator will not operate without water.

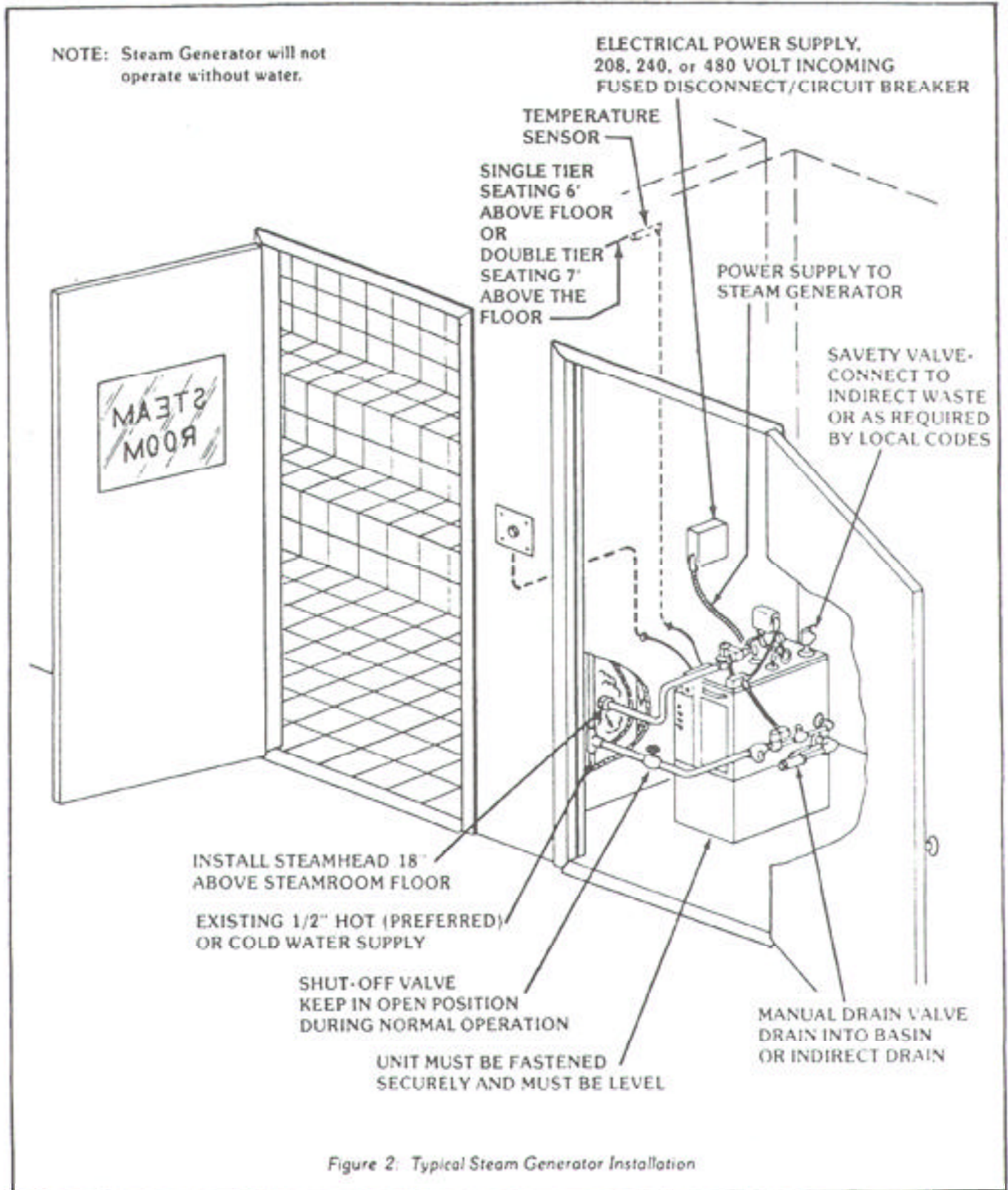

Figure 2: Typical Steam Generator Installation



## CP-1 CONTROL PACKAGE

- 2) Install the cable from the area of the Temperature Sensor (Probe) to the steam generator's location. The Temperature Sensor (Probe) MUST be located inside the steamroom. In steamrooms with singletier seating the Sensor should be located 6 feet above the floor, with two tier seating it should be 7 feet above the floor and in either case away from the steamhead and steamroom door. The connector end of the wire must be installed inside the steamroom. **NOTE: A 5/8 inch hole should be provided so that the connector can be passed through the wall for installation found later in these instructions.**

### CP-1 System Control Package Installation

- C. 1) Temperature Sensor (Probe) (for installation inside the steamroom)
  - a. Locate the 2 wire cable described in the Rough-in section.

- b. Keeping the 5/8 inch hole centered, drill two 1/4 inch holes 2 inches apart. Insert 2-No. 8 plastic anchors into drilled holes.

- c. Follow Figure 3.

- 2) Temperature Control Panel (for installation outside the steamroom )

- a. Attach the 3 wires (P1, P2, and P3) from the Temperature Control Potentiometer to the 3 wire cable in the two-gang box. Note the colors of wire P1, P2, and P3 are attached to match the colors of the 3 wire cable to the potentiometer wire colors.

- b. Secure Temperature Face Plate to the two-gang box using four (4) machine screws. (See Figure 4.) Important: Care must be taken to mount Temperature Face Plate properly.

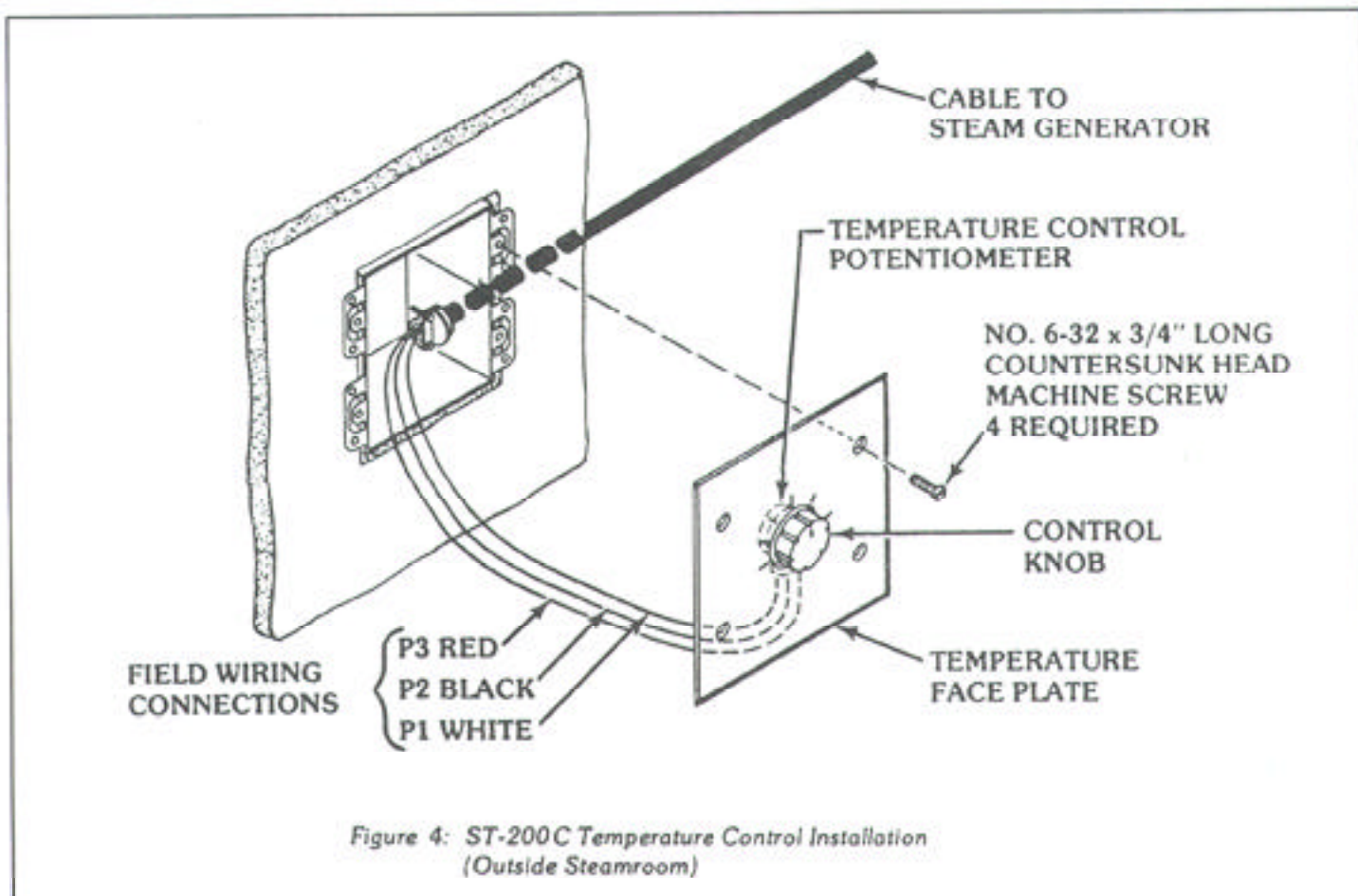

## CP-1 CONTROL PACKAGE

### 3) System Control Module

- a. Remove screws securing cover to System Control Module and remove cover (Figure 5).
- b. Feed the 3 wire cable through the top strain relief, three inches into the control module. Attach wires as shown in the blowup (Figure 5).
- c. Feed the 2 wire cable through the lower strain relief, three inches into the control module. Attach wires as shown in the blowup (Figure 5).
- d. Check that all connections are made

in accordance with Wiring Diagram (See Figure 7.)

- e. Replace control module cover.

### D. Steam Solenoid Valve

There is no installation required for the steam solenoid valve. it is factory installed and wired.

### E. Operation

The temperature of the steambath is regulated automatically by the ST-200C Temperature Control System which turns "On or off, the Steam Solenoid Valve located on the steam generator allowing steam to enter the room.

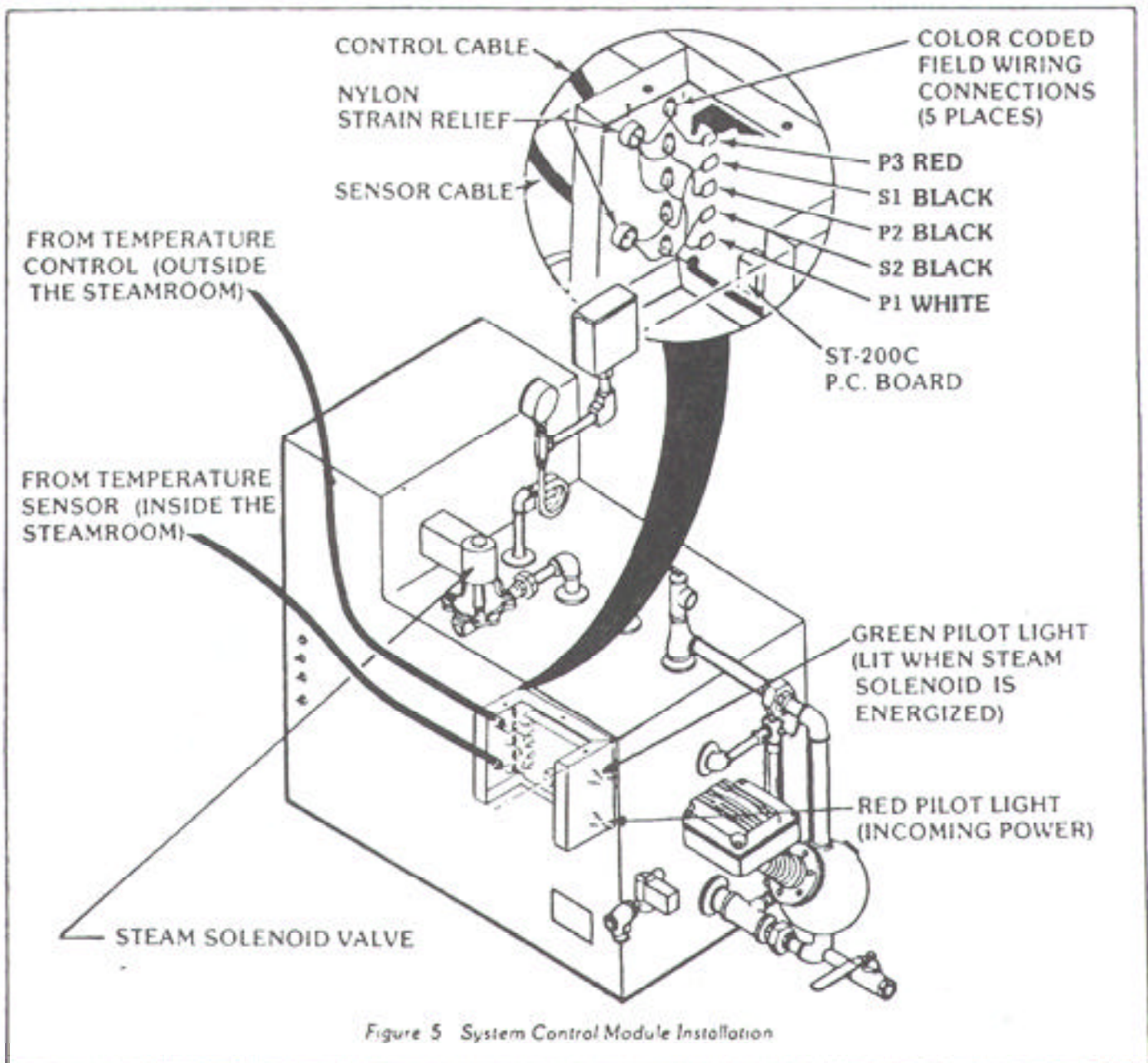

# CP-1 CONTROL PACKAGE

To INCREASE the temperature, turn the knob on the Temperature Control Panel clockwise; the HIGHER THE NUMBER, THE HIGHER THE SETTING (numbered 1 to 10).

To DECREASE the temperature, turn the knob counterclockwise.

Once a desired temperature setting has been established there should be no further need for additional adjustments.

**IMPORTANT.**

To check the function, two lights are provided on the exterior of the System Control Module located on the steambath generator. The "Red Light" indicates there is electrical power to the Temperature Control Module. The "Green Light" indicates the Steam Solenoid Valve is energized.

If a malfunction should occur in either the incoming electrical power supply "Red Light" or the Steam Solenoid Valve "Green Light" then the appropriate light will not be lit. However, the "Green Light" will cycle "ON and OFF" to indicate mode of the Steam Solenoid Valve.

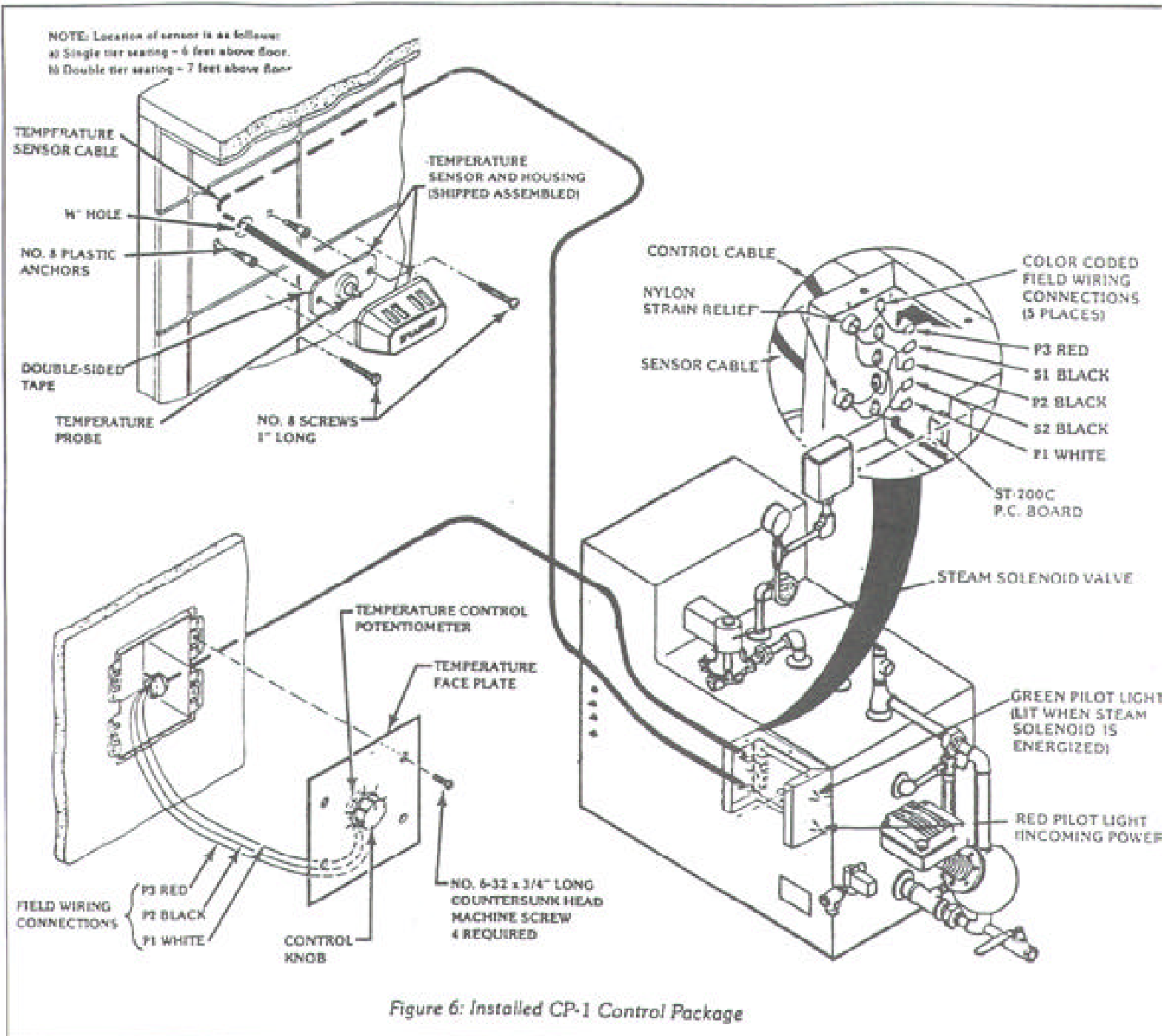

#### IV. AUTO BLOWDOWN AND AUTO ON/OFF TIME CLOCKS

The "HC" steam generator, with an optional auto blowdown system, will automatically purge the steam boiler. Working in conjunction, the Time Clock and electrically motorized valve, which allows blowdown on boilers, prevents excessive mineral and scale build-up.

##### A. Installation

###### 1. Auto Blowdown Drain Valve (plumbing)

Attach the main blowdown drain valve to 3/4" indirect drain (most local codes require a blowdown tank). A strainer must not be used with the valve. Note: the drain line must be angled downward, allowing gravity to properly drain the machine.

###### 2. Auto Blowdown (electrical)

All wiring is done at the factory so that no special electrical wiring is necessary.

##### B. Operation

First decide the TIME OF DAY you require the boiler to blowdown. It is recommended to select a time while the boiler is in use, but under low demand. For best results program the Timer to blowdown every day of use for a period of 5 minutes.

The blowdown will begin with the Timer "ON" command and end with the Timer "OFF" command. See Page 9 and 10.

##### C. SETTING AUTOMATIC ON/OFF TIME CLOCK

The Steam Generator will turn ON with the Timer "ON" command and OFF with the timer "OFF" command. See Page 9 and 10.

**IMPORTANT.** The Auto Blowdown Timer and Auto On/Off Timer are two separate timers. If your steam generator only has one timer, then only one of these two options can be programmed. Check with the installer to see which option has been purchased.

#### V. STEAM GENERATOR OPERATION

A. Place START, WATER SOLENOID, and STEAM SOLENOID switches in the ON position. The Water Solenoid Valve will open and the boiler will fill to its proper level (one-half to two-thirds of the sight glass full) and automatically shut-off.

B. When there is adequate water in the boiler the power contactor will energize and the red power light will illuminate indicating that the boiler is heating up.

NOTE: This boiler is equipped with a Solid State Liquid Level Control System. Water level is maintained in the boiler, by a ground potential signal between each stainless steel water level probe and the boiler, and operates by sensing the electrical resistance of water.

Both the water feed and low water cut-off functions are regulated by a low voltage electrical signal that activates the control relay(s), depending on the water level within the boiler which, in turn, energizes the water solenoid valve and/or power contractor.

C. When adequate steam has been generated from the boiler and the desired temperature reached in the steamroom the steam solenoid valve will close: when controlled by the ST-200C. The steamroom is now ready for use. Note: When the steam solenoid valve closes the red pilot light above the toggle switches will go out only after steam pressure builds to approximately 8 to 10 PSI within the boiler.

The boiler will maintain an 8 to 10 PSI steam pressure by use of a pressure control which is supplied as standard equipment. The pressure control will cycle the unit ON and OFF automatically when the steam solenoid valve is OFF and the room temperature control is satisfied. If the solenoid valve is OPEN, the pressure in the boiler will drop and the red light will stay ON.

D. If a ST-200C Temperature Control System (Thermostat) is provided, set the dial to the desired TEMPERATURE (Dial Calibration: 1 to 10 setting for comfort level). (Refer to Section III for Operating Instructions.)

E. If an Automatic ON/OFF Time Clock is provided, set "the timer cycle" in order to operate the steambath generator.

#### VI. STEAM GENERATOR MAINTENANCE

A. **MANUAL BLOWDOWN** (Only if not equipped with Automatic Blowdown)

The boiler should be blown down on a daily basis to purge the vessel of mineral deposits and possible scaling. For effective blowdown, the STEAM, WATER, and START switches must be placed in the OFF position. The drain valve should be opened completely, allowing the boiler water to exit through your drainage piping into an indirect drain. Now, place the water solenoid switch in the ON position allowing the system to flush through for approximately 5 minutes. Close the drain valve and allow the boiler to fill with water until the proper level has been reached. The generator is again ready for use, place the START and STEAM switches in the ON position.

##### B. PERIODIC INSPECTION

CAUTION: Disconnect all power to boiler before servicing. Service should be performed by a qualified person.

1. Check electrical connections periodically, to ensure that they are tight.
2. Remove the lower section of the HcDonnel/Miller 150 series Control and low water cut-off periodically to check for deposits. Check that the float and rod Inside the round chamber are not coated with deposits and the float moves freely without sticking. Check that the bottom pipes from the boiler opening to the float chamber are free of debris.
3. Remove flange-type element to clean any scale that might have built up on sheath of heating element(s). Be careful when cleaning heating element, not to deform the rods.

# Digi 20 Series

## One Circuit Electronic

### 24 Hour or 7 Day Time Switches

FIGURE 7. Auto Blowdown and Auto ON/OFF Timeclock



Digi 20A  
(surface mounting)

## Operating Instructions

### APPLICATION

Time based control of lighting, ventilating, heating, cooling or other electrical loads in commercial and industrial applications. The Digi 20 time switches are programmable for 24-hour or 7-day schedules.

The Digi 20A is intended for either surface or rail mounting. The control is completely enclosed in a plastic housing and includes a terminal cover and sub-base for installation and hard wiring.

The Digi 20E is intended for flush (panel) mounting.

All units are supplied with a clear plastic dust cover.

### TECHNICAL DATA

Output-1 SPDT relay with dry contacts

Switch Rating: 16A/277VAC resistive

1 000W tungsten @ 240VAC; 500W @ 120VAC

1/2 hp @ 120VAC; 1 hp @ 240VAC

100 hour capacitor back-up of memory and display

Supply voltages: Separate Models - 24VAC/DC, 120VAC,  
208/240VAC, all 50/60Hz (refer to product label)

Shortest switch time-1 minute

Ambient Temperature Range -20° F to 140° F ( -28 °C to 60° C)

VA required: 120V & 240V models: 4VA

24V model: 2VA @ 24VAC, 1VA @ 24VDC

Screw terminal connections (Digi 20A)

1/4" quick connects (Digi 20E)

Accuracy ± 4 minutes per year

### WIRING

1. Disconnect the power.

2. Wire input to timer (M) to the proper voltage marked on the unit. Wiring to incorrect voltage will void the warranty.

3. Connect wiring according to the wiring diagram. The terminals on the Digi 20A sub base will accommodate 10 to 24 AWG wire.

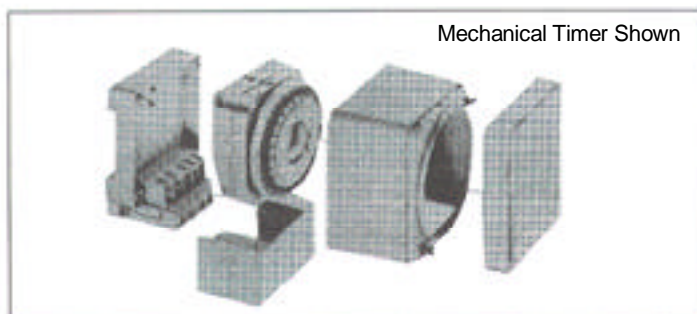
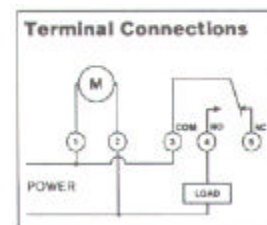

# Digi 20 PROGRAMMING INSTRUCTIONS

The circular keypads are positioned to provide a sequential path for programming. Starting with **Prog.** to select a program, clockwise to **⊗** to select ON or OFF, then **h** for hour, **m** for minute, and finally **Day** to select day or days of the week. If an input is missing or incomplete, the missing segments will flash when the ⊗ or program key is depressed. (For example, if no ON or OFF is selected, the ON symbol will flash). The missing entry must be completed before programming can resume. While programming, pressing the **h**, **m**, or **Day** key longer than 2 seconds will cause a rapid roll of the parameter.

- A program consists of: 1. ON or OFF command, 2. Hour and minute, and 3. Day or multiple days on which it is to occur.
- **Res.** is the reset key which clears the time of day and deletes all program information.
- The **±1h** key sets clock time up or down 1 hour for daylight savings time adjustment in the spring and fall.
- Military (24:00 hr.) or AM/PM (12:00 hr.) time may be selected by pressing and holding the **h** key while depressing the **±1h** key.

**Note:** A flashing display indicates either incomplete data entry or the battery is low. Check to see if days and ON or OFF times are entered and check the power supply to the time control.

## IMPORTANT: Depress reset key before beginning to set time and program

### SETTING TIME AND DAY OF CLOCK

1. Select military (24:00 hr.) or AM/PM (12:00 hr.) time mode by depressing and holding **h** key while pressing **±1h** key to toggle between military and AM/PM. (AM appears in display when in AM/PM mode.)
2. Press and hold down **⊗** key.
3. If setting the time when daylight savings time is in effect, press **±1h** key once (+1h will appear in display).
4. Set hour with **h** key. If AM or PM does not appear in display, the unit is in military time. See note above to change display.
5. Set minutes with **m** key.
6. Press **Day** key repeatedly to the day of the week. (1 is Monday, 7 is Sunday)
7. Release **⊗** key, colon will begin flashing. If the days are flashing, the day of the week was not entered (see step 6).

### PROGRAMMING

1. Press **Prog.** key 

1	2	3	4	5	6	7
AM	-	-	-	-	-	-

 will appear in display. (Pressing **Prog.** key again, display will show the number of free programs: **Fr 20**). Press again to return to 1st program.
2. Press **⊗** key, **⊙** ON symbol will appear. Pressing the key again will toggle to OFF **⊖**. Select ON or OFF for the program with the **⊗** key.
3. Press **h** to select hour for switching time.
4. Press **m** to select minute for switching time.
5. If the program is to occur every day of the week, (24 hour time control) ignore **Day** key and press **Prog.** key to advance to next program.
6. If 7 day time control is desired, press **Day** key. 1 2 3 4 5 6 (Mon thru Sat) block of days appears in display. Pressing **Day** key again, 1 2 3 4 5 (Mon thru Fri) appears in display. Pressing **Day** key again, 6 7 (Sat & Sun) appears in display. Pressing **Day** key again, 1 (Mon) appears in display. Repeated presses will cycle through all days of the week, and back to 1 thru 7 (Mon thru Sun). Select day or block of days desired with the **Day** key.
7. Press **Prog.** key and repeat steps 2 thru 6 to enter additional programs of ON and/or OFF times (Note that more than one OFF time program may be entered, enabling automatic control of manual overrides.)
8. Press **⊗** key to enter run mode.

**IMPORTANT: The output relays will switch ON (or OFF) only at the programmed times. After programming is completed, if a channel should be ON, it must be manually turned ON with the **⊗** key. For example, programming is completed at 2PM and CH1 was programmed to be ON at 8AM and OFF at 5PM. After pressing the **⊗** key, CH1 will be OFF; press **⊗** to turn it ON. It will assume automatic operation at the 5PM OFF time.**

### REVIEW AND CHANGE OF PROGRAMS

1. To review a program at any time, press **Prog.** key. Programs will be displayed in the sequence they were entered with repeated presses of **Prog.** key.
2. To change a program, select the program to be changed with the **Prog.** key, and enter the new time of day, and/or days of week just as in the programming steps shown above. The old program is overwritten with the new selections. Press **Prog.** to store the new program.
3. To delete an individual program, select the program as in step 1 and press the **m** key and then the **h** key until "—:—" appears in display. Press either **Prog.** or **⊗** key until "—:—" flashes. The program is deleted after a few seconds.

### MANUAL OVERRIDE

While in the **Run** mode, (**⊗** symbol is display), pressing the **⊗** key will reverse the load status (switch load OFF if it is ON, or switch ON if it is OFF). A hand symbol appears in display to indicate the override is active. At the next scheduled switching time, automatic time control will resume, eliminating the override.

- Pressing the **⊗** key a second time **Ⓜ** appears in the display indicating the load is switched **permanently ON**.
- Pressing the **⊗** key a third time, **Ⓜ** appears in the display indicating the load is switched **permanently OFF**.
- Pressing the **⊗** key a fourth time returns to automatic, **⊗** appears in the display.

**If problems occur with timer control only, contact:**

**GRASSLIN CONTROLS CORPORATION**

31 Industrial Ave., Mahwah, New Jersey 07430 • Tel.: 201-825-9696 • Fax: 201-825-8694

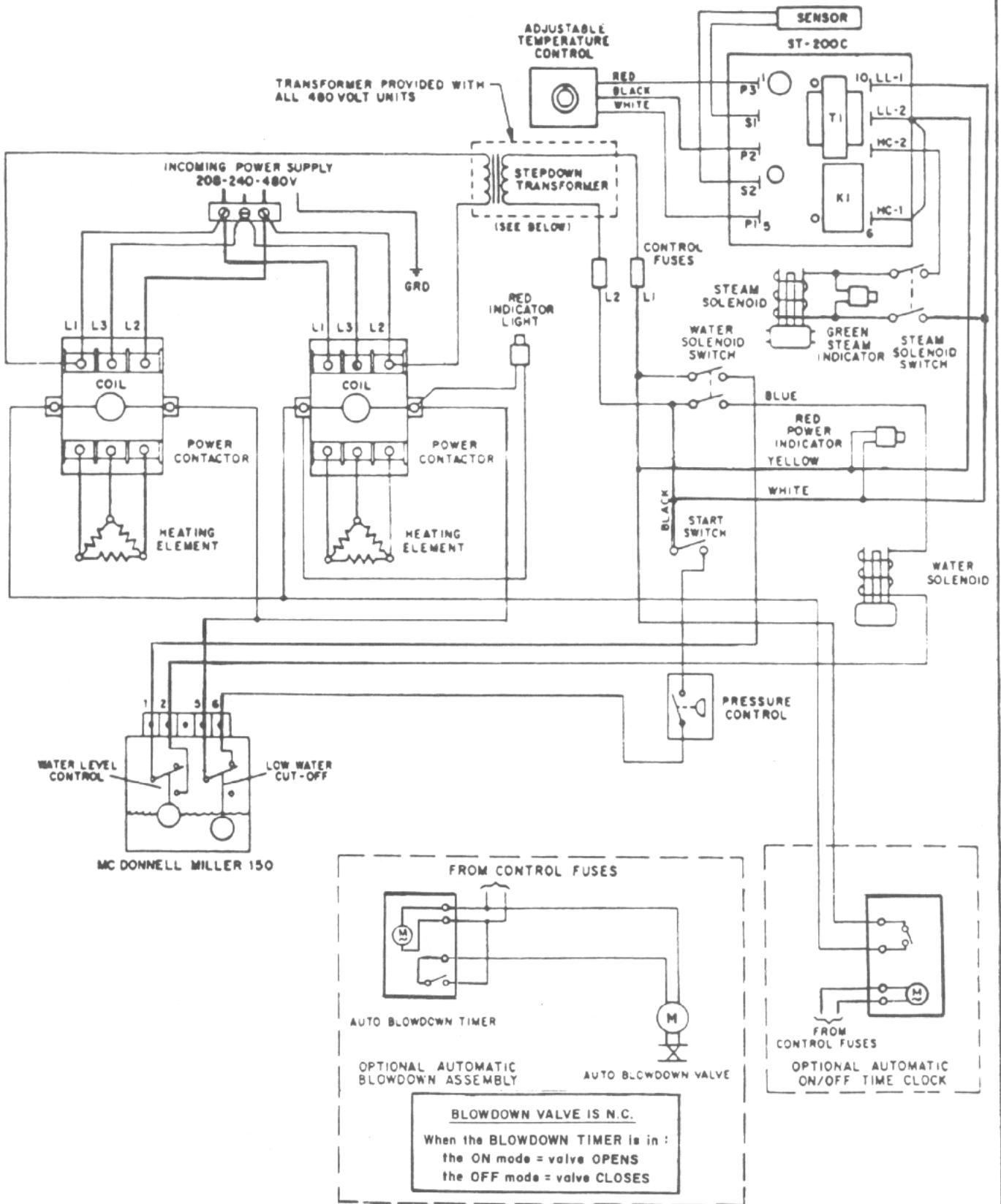

Figure 8  
"HC" WIRING DIAGRAM WITH OPTIONS

