

Electrical Installation Instructions



WARNING: Elderly persons, pregnant women, or those suffering from heart disease, high blood pressure, diabetes, or who are otherwise not in good health, do not use this device unless directed to do so by a physician. Also, do not use steambath while under the influence of alcohol.

IMPORTANT: the warranty of this product is voided if it is used in a commercial application or for anything other than a residential steambath installation. All electrical connections must be performed by a licensed electrician in accordance with Local and National Electric Codes.

The Steamist “SM” generator operates with one or two controls appropriately located inside and/or outside the steamroom. It’s small enough in size to be tucked away using very little space in a vanity, closet, basement, or an insulated attic, but large enough to provide steam for most residential baths.

The Steamist “SM” Steambath Generator comes factory-assembled carefully wired and tested.

NOTE: The TC-110, TC-135, DSC-425, and DSP Controls are designed to work with all Steamist “SM” Generators.

1. Pre-Installation

- Proper electrical supply (208 or 240 Volt): See rating label on Steam Generator and Chart on back page. Determine proper size of wire, voltage, amperage, and phase for the Steam Generator. Only UL rated 90°C wire can be used.
- In-line fuse/circuit breaker required: Fuse/circuit breaker to be installed must be sized in accordance with chart on back page. Do NOT install a GFI (Ground Fault Interrupter) to this equipment (per article 210-8 in the National Electric Code).
- Route power supply cable to the location where the Steam Generator will be installed (before walls are closed).

2. Electrical Rough-In

- Route appropriate power cable to the location the Steam Generator will be installed. If receptacle is desired, mount the box for the receptacle near the location of the Steam Generator (See Figure 3: Typical Installation).

NOTE: The plug and receptacle require a rating of no less than 250V and proper amperage. Refer to chart on page 4 for amperage rating.

After the walls are complete, the Steam Generator and Control can be wired.

3. Steam Generator Electrical Installation

WARNING: All power to the steam generator must be turned off.

- Remove the six screws holding the electrical access cover and remove cover.
- Locate the supply line knockout. Mount proper strain relief into knockout hole.
- Strip back power cable’s outer insulation jacket eight inches and insert into steam generator. Strip back insulation 1/2” from the three (3) incoming wires (two power and one ground).
- Insert ground wire into grounding lug located on the right side of the electrical compartment and secure.

CAUTION: Be sure the ground wire does not come in contact with a live electrical part.

- Locate the terminal block in the upper portion of the electrical box. Insert power wires into the power lugs on the right of the terminal block and secure.

4. Optional Auto Drain Valve Connection

- Open knockout for Auto Drain Valve conduit connection.
- Route flexible conduit from valve to knockout and secure.
- Connect two wires from valve to the two place terminal strip provided (See figure 2).

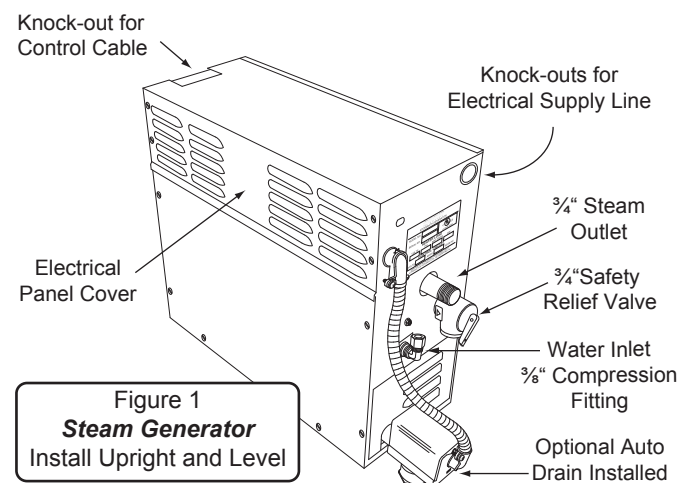
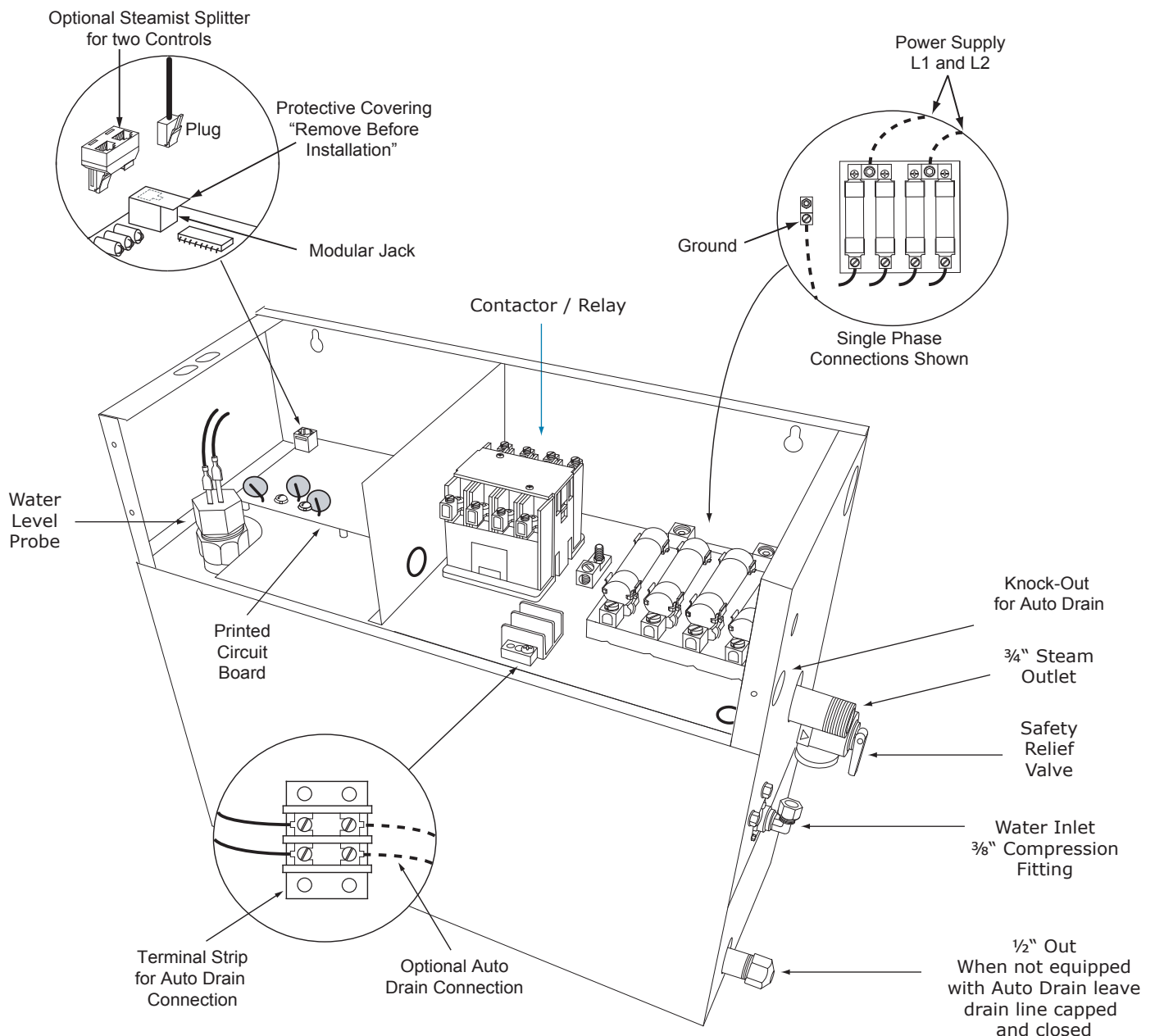

Figure 1
Steam Generator
Install Upright and Level

Checklist

Before starting, insure that the conditions of the following checklist have been met:

- The proper size Steam Generator has been selected by using the sizing page in the "Full Line Brochure," "Pricing Guide," or "The Generator Sizing Guide" in the Residential Systems/Steambath Product Information section of the Steamist web site - www.steamist.com.
CAUTION: An improperly sized Steam Generator will NOT produce the amount of steam necessary to reach selected temperature.
- The Steam Generator is installed in an upright position.
- The proper sized 90°C wire and circuit breaker have been used.
- The circuit breaker is NOT a GFI (Ground Fault Interrupter) type.
- The Steam Generator is properly grounded.
- The circuit breaker or disconnect switch is on.
- Water Supply is open to the Steam Generator.
- The proper voltage Steam Generator has been selected (i.e., 208V or 240V). A 208V generator operating on 240V will damage the heating element and a 240V Generator operating on 208V will result in a 25% loss of power.



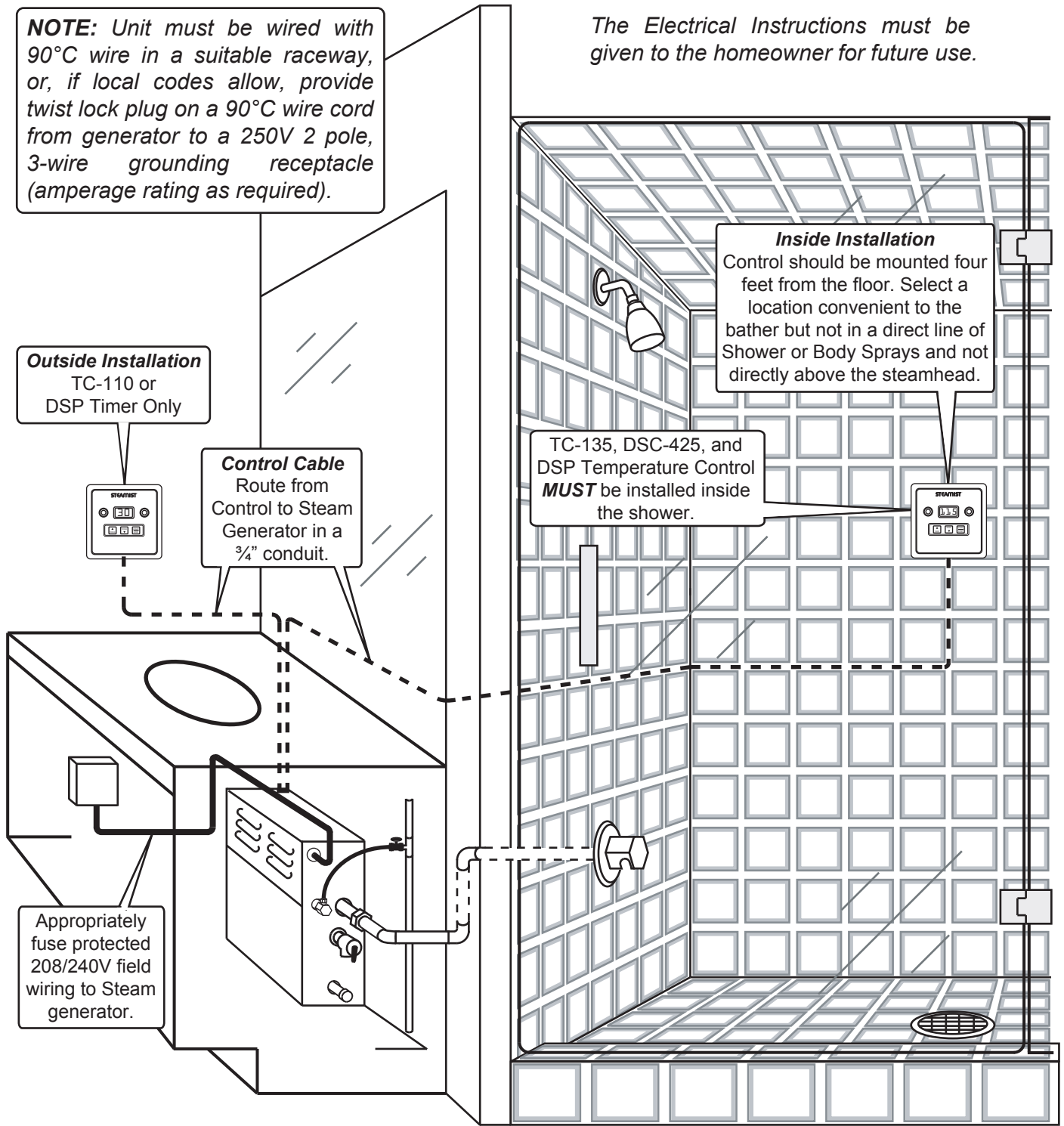

IMPORTANT: Run the Control Cable through a 3/4" conduit. Remove protective cap when making the final connection to Control.

Figure 3: Typical installation

SM-12/15 SINGLE PHASE SCHEMATIC

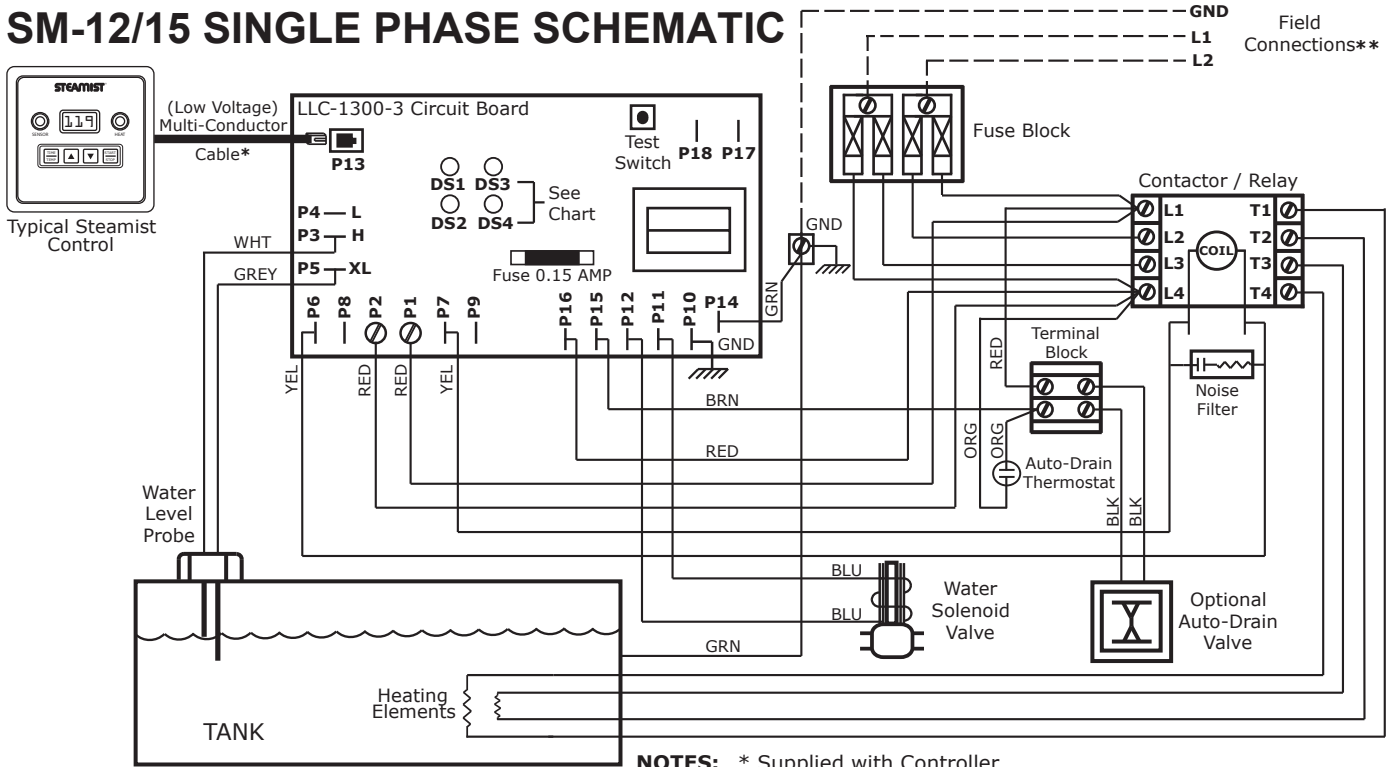

NOTES: * Supplied with Controller.
 ** Field Connections, use 90°C wire, gauge No. See Chart Copper.

SPECIFICATION CHART							
Model No.	Max. Cu. Ft. For Area Up To	KW	Volt	Phase	Amps	Wire Size 90°C Copper AWG	Line Fuse
SM-12	450	12	240	1	50	6	70
			208	1	58	4	80
			240	3	29	8	40
			208	3	33	8	45
SM-15	550	15	240	1	63	4	80
			208	1	72	4	90
			240	3	36	8	45
			208	3	42	6	60

LED COLOR CHART		
DS1	GRN	TIMER ON
DS2	YEL	HEAT ON
DS3	AMB	WATER FILL ON
DS4	RED	POWER ON

SM-12/15 THREE PHASE SCHEMATIC

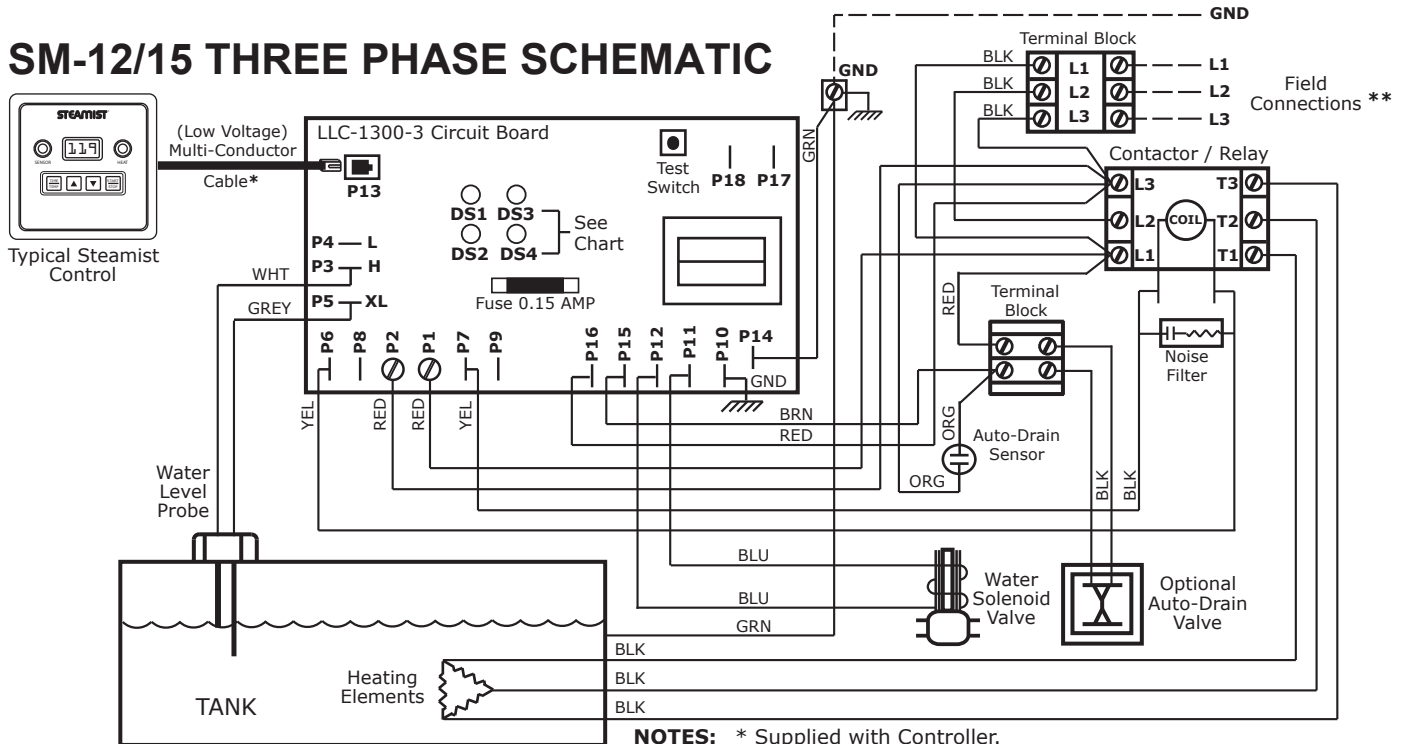

NOTES: * Supplied with Controller.
 ** Field Connections, use 90°C wire, gauge No. See Chart Copper.

Plumbing Installation Instructions



WARNING: Elderly persons, pregnant women, or those suffering from heart disease, high blood pressure, diabetes, or who are otherwise not in good health, do not use this device unless directed to do so by a physician. Also, do not use steambath while under the influence of alcohol.

IMPORTANT: the warranty of this product is voided if it is used in a commercial application or for anything other than a residential steambath installation.

The Steamist “SM” Generator comes factory assembled, carefully wired and tested.

The Plumbing Installation must conform to local and national codes. All electrical power should be turned OFF when working with Steam Generator.

1. Pre-Installation

- a) Be sure that the proper size Steam Generator has been selected by using the sizing page in the “Full Line Brochure,” “Pricing Guide,” “The Generator Sizing Guide,” “Architectural Guidelines,” or in the Residential Systems/Steambath Product Information section of the Steamist web site - www.steamist.com.

CAUTION: An improperly sized Steam Generator may NOT produce the amount of steam necessary to reach selected temperature.

- b) **IMPORTANT:** Refer to page 4 for model required for cubic foot rating.

The Steam Generator should be located as close as possible to the Steam Room/Shower or tub enclosure. Steam pipe should NOT exceed twenty-five feet in length. If the steam pipe exceeds ten feet, use an appropriate pipe insulation rated for a minimum of 212°F. Possible locations include Vanity, Closets, Attic (insulated), or Basement near bath area. The serial number plate should be visible and the Steam Generator should be accessible for service. Refer to Installation Suggestion on the page 4. Do NOT install Generator outdoors, in a moist humid area, or in an area where parts may freeze or corrode. Also, do NOT install near flammable materials such as paints, thinners, gasoline, etc.

The steam line and safety valve reach a temperature of 212°F during operation and should be appropriately protected to prevent personal injury by accidental contact.

2. Plumbing Rough-In

Plumbing rough-in is required for the water supply and steam line, this should be completed before the walls are closed. For operation, the “SM” Steam Generator requires a 3/8” O.D. copper tubing to the fitting on the generator for water inlet and 3/4” copper or brass pipe for steam outlet.

NOTE: Safety Valve should be connected to a minimum 3/4” indirect waste or as required by local plumbing codes. In the unlikely event this valve should open, the discharge must be directed to prevent damage to the home.

- a) **Water Inlet** - A water line should be roughed-in from existing 1/2” hot or cold water pipe. Using a 1/2” x 3/8” tee, cut and solder tee into the existing water line. (See Figure 3 on page 3). Solder a piece of 3/8” copper tubing into tee. Rough-in for water supply is now complete.
- b) **Steam Outlet** - Rough-in the steam line using a minimum of a 3/4” copper or brass pipe, do NOT use black iron or galvanized pipe, it will rust and discolor the wall of the steam bath. The steamhead location should be 18” above the shower floor or 6” above the rim of the bathtub, as far from the seating area as possible.

CAUTION: No shut-off valve can be installed in the steam line. Do NOT create traps or valleys in this line which would trap condensation and block the flow of steam. The steam pipe should be pitched toward the Steam Generator allowing condensation to run back toward the Steam Generator (preferred), or toward the steamhead.

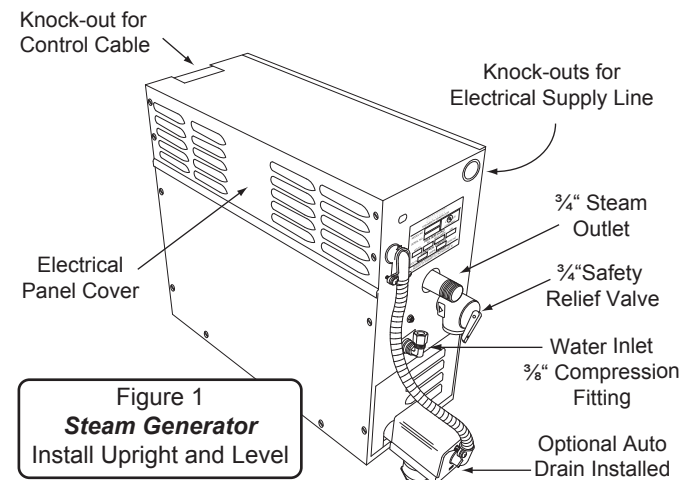

3. Steam Generator Installation

The Steam Generator should be mounted in a location convenient for hook-up and service by the Plumber and Electrician.

CAUTION: The steam generator is designed to be used ONLY in an upright and level position, to do otherwise would damage the unit and void the warranty.

- The steam generator can be mounted to a wall or set on the floor. However, the unit must be secured. To secure the unit to a vertical wall, loosen the two screws holding the electrical access cover, remove cover (see Figure 1). Located inside the cabinet near the top left and right corners are mounting holes. Place top cover back and secure.
- Connect the 3/8" water supply, described in Section 2 to the Steam Generator by first soldering a 3/8" valve into the previously installed water line. The valve must be kept in an open position during normal operation. In areas where high water pressure may be a problem a water hammer arrestor or a pressure regulator should be installed. Complete water supply by connecting 3/8" copper tubing from the valve to the water inlet compression fitting. Refer to Plumbing Diagram below.

IMPORTANT: Do NOT use a "saddle valve" or piercing type valve for water connection.

- Connect the steam line from rough-in location described in Section 2 to the 3/4" nipple on the steam generator using a union.
- In the shower, place the center of the escutcheon onto the steam pipe and screw the steamhead into place. Care must be taken not to scratch the steamhead or escutcheon with wrench. Be sure the steam slot in the steamhead is facing down. After the plumbing connections are complete the electrician may finish wiring the unit.

Installation Instruction for Steamhead & Escutcheon

(Supplied with control package)

- Be sure the steam pipe is installed with the proper length pipe protruding through the wall.
- Apply silicone sealant around the pipe to seal the pipe to the wall.
- Slip the Escutcheon over the steamhead loosely.
- Screw on the steamhead making sure the steam opening is facing down.
- Hold the Escutcheon against the wall and tighten the retaining screw facing down.

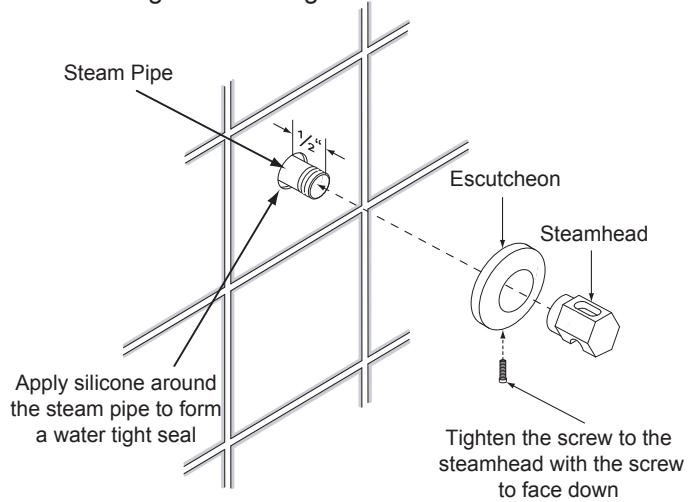

WARNING: When installing a steam pipe into a steam room made out of Acrylic, Cultured Marble, Corian, Swanstone, Resin, Plastic or an equivalent type of material, consult the manufacturer of the material for their recommendation on location of the steam pipe. Verify that the type of material used for the construction of the steam room is rated for a steam room environment. When installing a steam pipe, in the mentioned material type rooms, it is very critical in making sure that when the steam pipe protrudes into the steam room that it is centered in its 1 1/4" hole and does not touch the edge of the wall material around the steam pipe.

IMPORTANT: An optional steam diffuser (Not Included) is strongly recommended for small steam rooms. This option helps to better diffuse the steam and makes the steam bath more comfortable. This option may not be necessary in larger steam rooms where the bather is sitting a few feet away from the steamhead.

IMPORTANT: Install steam head 18" above the shower floor or 6" above the rim of the Bathtub.

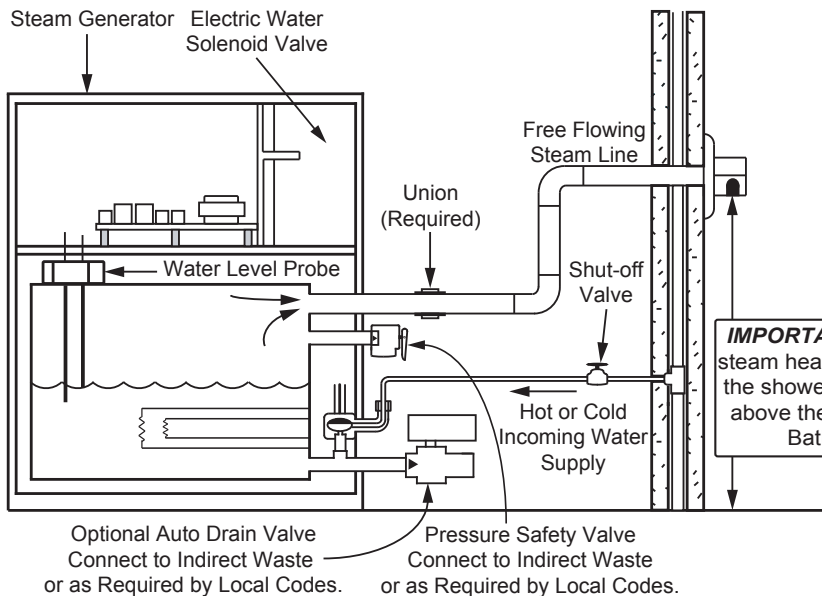

Figure 2: Plumbing Diagram

WARNING: When installing the Steamist Unit in conjunction with an acrylic modular tub/shower unit, please consult the “**manufacturer of the module**” for location of the steamhead.

The Plumbing Instructions must be given to the homeowner for future use.

Slope ceiling 2” per foot

Outside Installation
TC-110 or DSP Timer Only



TC-135, DSC-425, and DSP Temperature Control **MUST** be installed inside the Steam Room.



3/8” Shut-off Valve
Keep in open position during normal operation.

1/2” x 1/2” x 3/8” Tee.
Using existing Hot or Cold water supply.

Steamhead Installation
Steamhead should be mounted 18” above the finished floor or 6” above the rim of the tub as far from the bather as possible.

Union Required

A 3/8” air gap is recommended below the door and the door should incorporate a splashguard. The top and sides of the shower opening must be sealed.

Safety Valve
Connect 3/4” pipe to an indirect waste or as required by Local Codes.

Steam Outlet Pipe - Use a minimum of a 3/4” Copper or Brass pipe.
CAUTION: Do NOT install a Shut-off valve on the Steam outlet pipe. Do NOT create traps or valleys in this line which would prevent the flow of steam. The steam outlet pipe should be pitched toward the Steam Generator (preferred), allowing condensation to run back into the Steam Generator or toward the steam head. If the steam pipe exceeds ten feet, use an appropriate pipe insulation rated for a minimum of 212°F.

Figure 3: Typical installation

Access Requirements

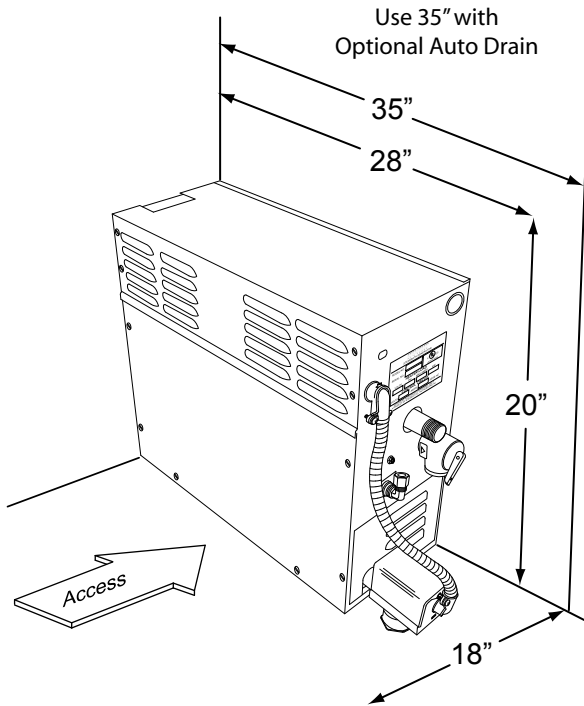

Select a location for mounting the Steam Generator that is accessible for installation and service. The access requirement indicates the minimum space for convenient access to Steam Generator.

CAUTION: All models must be installed INDOORS, in a DRY, NON-FREEZING location away from flammable materials such as: Gasoline, Paints, Thinners, Etc...

IMPORTANT: Steam Generator must be installed upright and level.

SPECIFICATION CHART							
Model No.	* Max. Cu. Ft. For Area Up To	KW	Volt	Phase	Amps	Wire Size 90°C Copper AWG	Line Fuse
SM-12	450	12	240	1	50	6	70
			208	1	58	4	80
			240	3	29	8	40
			208	3	33	8	45
SM-15	550	15	240	1	63	4	80
			208	1	72	4	90
			240	3	36	8	45
			208	3	42	6	60

* Refer to the Steamist Sizing Guide for actual Cu. Ft. capacity.

Installation Suggestions

Alternate Attic Location
(Insulate to Prevent Freezing)

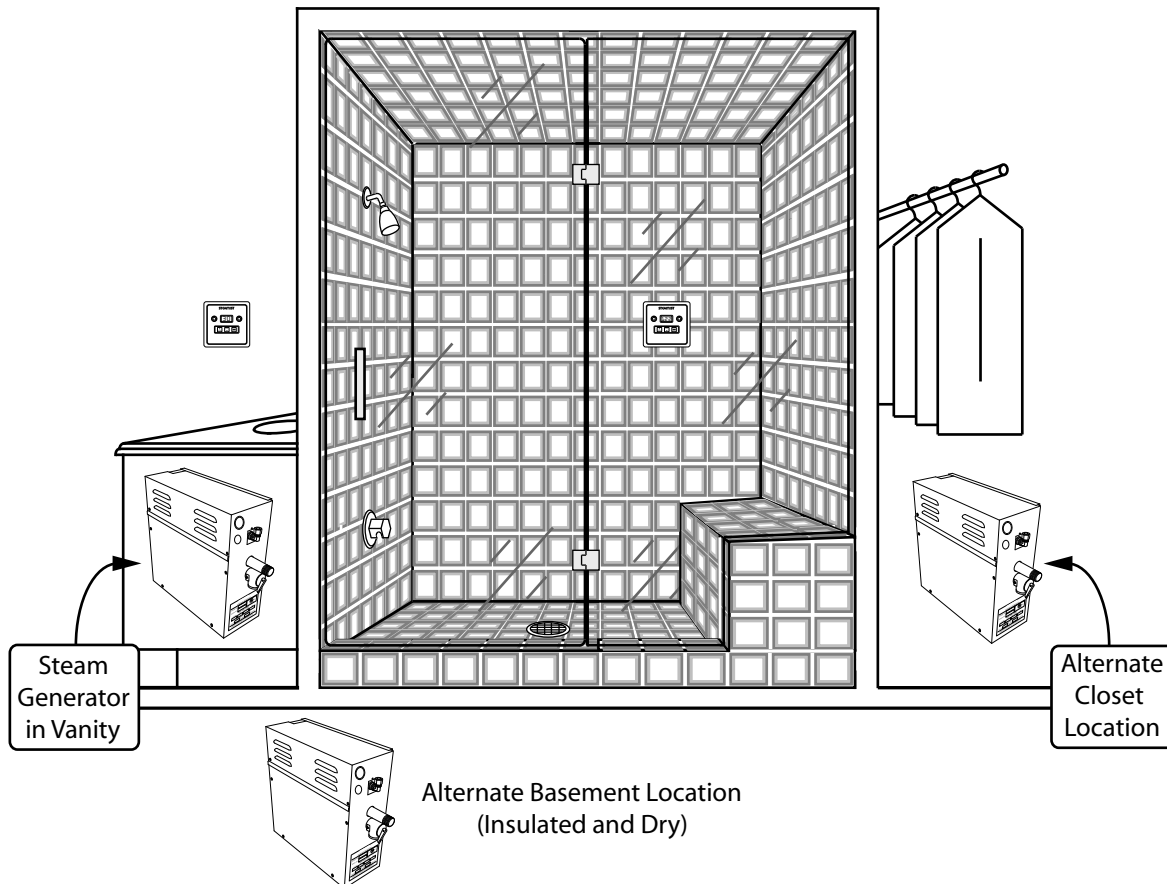
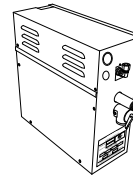

Warning: Do not turn on the power to the steam generator until the installation is complete and the unit is ready to test/use. If the steam generator will not be in use for long periods of time (over 6 months) the power to the steam generator should be turned off.

Important: In order for the InstaMist feature to function, water must always be in the tank. For this reason the Optional Auto-Drain can *NOT* be used with any InstaMist generators.

The Steamist InstaMist Feature (-IM) is only available as a factory installed option on the following Models: SM-5, SM-7, SM-8, SM-11, SM-12, SM-15, System-18, System-24, and System-30.

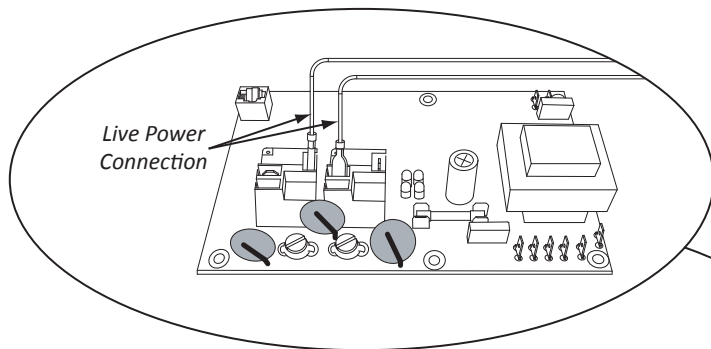

INSTAMIST

The Steamist InstaMist generators feature pre-heat function, which provides a generous volume of steam in under a minute. This new feature maintains an average water temperature of 180°F in the stainless steel reservoir. When the steam generator is activated, the pre-heated water inside the steam generator quickly reaches the boiling point, allowing steam to flow out in under a minute.

All Steamist steam generators with or without InstaMist are factory assembled and tested. There are no additional Plumbing or Electrical requirements needed in the field for generators with the InstaMist feature. The installation instructions for the plumber and the electrician are provided with the steam generator and need to be followed.

