

BATHOLOGY

rediscover bathing



Spectrum 620-C & 626-C

Color Light Salt Panel

Installation and Operation Manual

Contents

Installation Considerations -----	3
Installation - Overivew -----	4
Installation - Himalayan Salt Panel (Interior (Phase 1)) -----	10
Installation - Himalayan Salt Panel (WIFI (Phase 1)) -----	11
Installation - Himalayan Salt Panel (Remote (Phase 1)) -----	12
Installation - Himalayan Salt Panel (Phase 2) -----	14
Operation - Interior -----	15
Installation - Himalayan Salt Panel (WIFI (Phase 3)) -----	16
Operation - WIFI -----	17
Installation - Himalayan Salt Panel (Remote (Phase 1)) -----	18
Operation - Remote -----	19
Specifications -----	20
Replacement Parts -----	20
Notes -----	21

Installation Considerations

Please read this manual in its entirety prior to installation

CAUTION Carefully review all installation options and instructions before proceeding.

CAUTION For safety purposes, use safety goggles at all times.

WARNING If there is any risk of uninsulated electrical connections in your wall / ceiling area, use insulating gloves.

! IMPORTANT Prior to installation, consider the placement carefully, taking into account the location of electrical, plumbing, and other fixture.

! IMPORTANT The Spectrum 620-C and 626-C require a minimum of 4" at both ends to insert or remove center salt block for mounting or removing panel.

! IMPORTANT Power Supplies and Receivers should be installed outside of the bathing environment. Do not install in Sauna Environment.

! IMPORTANT It is recommended that all electrical equipment be tested prior to installation.

! IMPORTANT The Spectrum 623 wall mounted interior control can be installed outside of the Sauna environment, 48" above the floor, on a vertical wall, convenient for operation. It can also be installed inside the Sauna environment, 36" above the floor maximum.

! IMPORTANT Each Salt Panel Assembly may weigh up to 55 lbs and require additional framework or support. 3/4" Plywood is recommended to help support the weight of the fixture(s).

Spectrum 620-C & 626-C

Installation - Overview

Note: It is recommended that all electrical equipment be tested prior to installation.

Note: Illustration below showcases Spectrum 620-C Himalayan Salt Panel Assembly which measures 48x12. Spectrum 626-C operates similarly, but measures 16x16. Surface mount shown.

Sauna Environment

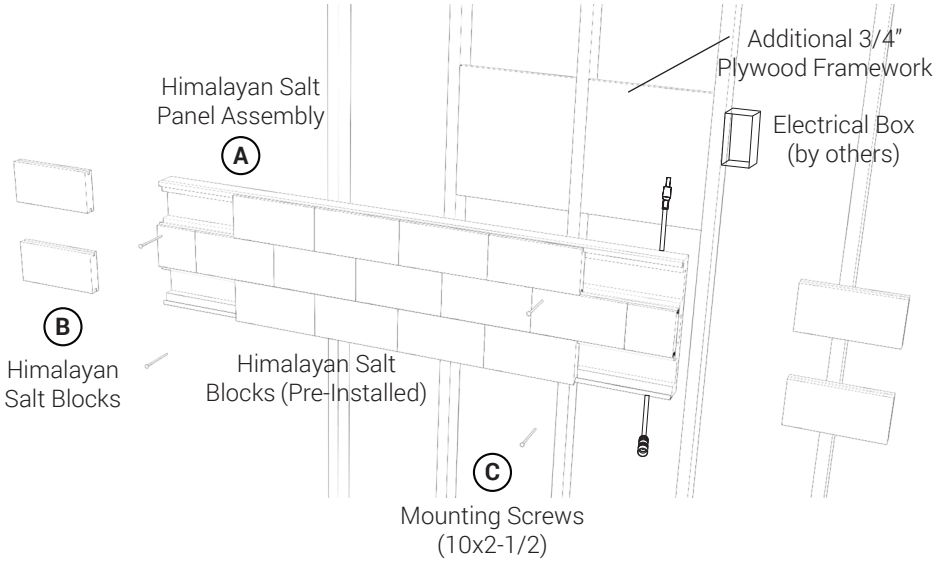

Package Includes

Spectrum 620-C		
Item	Quantity	Description
A	1	Himalayan Salt Panel Assembly (Salt Pre-Installed)
B	4	Himalayan Salt Blocks
C	4	Mounting Screws (10x2-1/2)

Spectrum 626-C		
Item	Quantity	Description
A	1	Himalayan Salt Panel Assembly (Salt Pre-Installed)
B	4	Himalayan Salt Blocks
C	4	Mounting Screws (10x2-1/2)

Note: Control is required to operate this system.
For details on those controls, please see the following:

Spectrum 623 - Wall Mounted Interior Control: Page 6

Spectrum 625 - WIFI / Alexa: Page 8

Spectrum 631 - Remote (Color): Page 8

Spectrum 620-C & 626-C

Package Includes

Spectrum 623 - Interior		
Item	Quantity	Description
E	1	Light Extension Cable
F	1	DMX Decoder
G	1	Power Supply
H	1	DMX Cable
I	1	Power Connector
J	1	Touch Interface

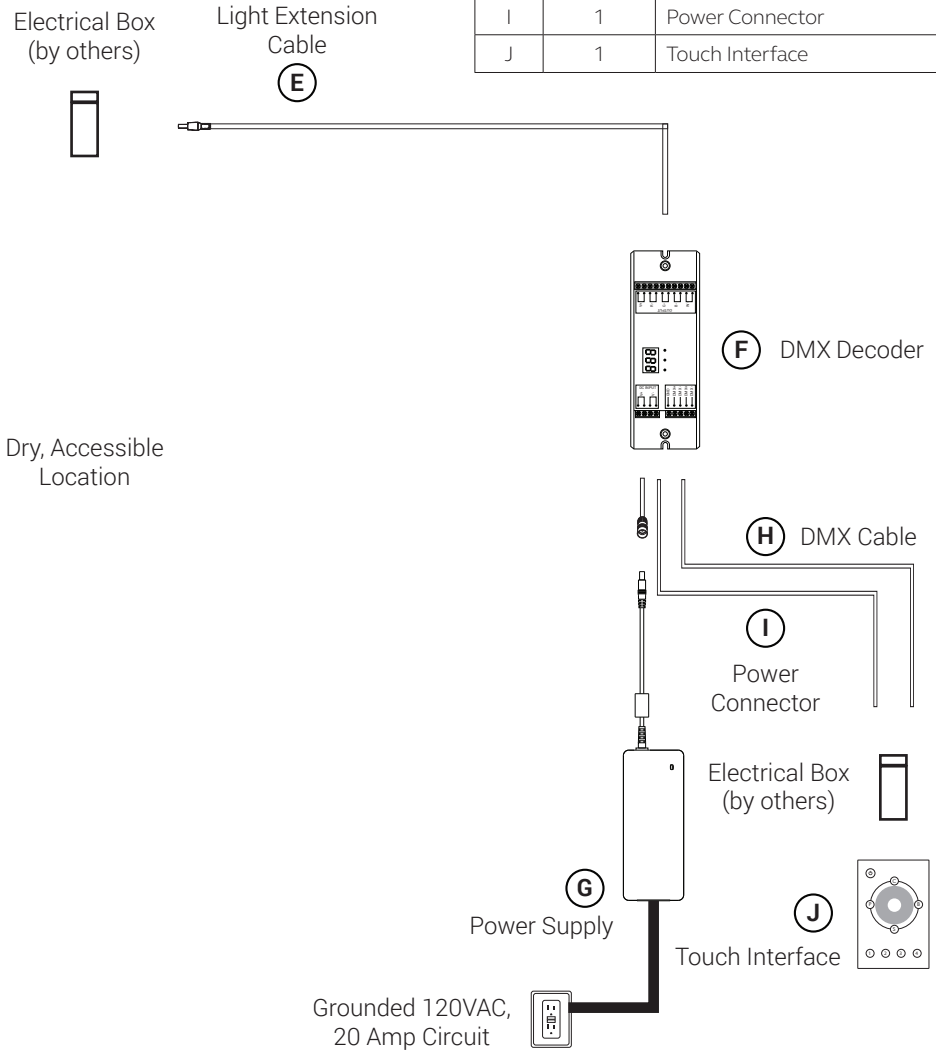

Spectrum 623 - Interior

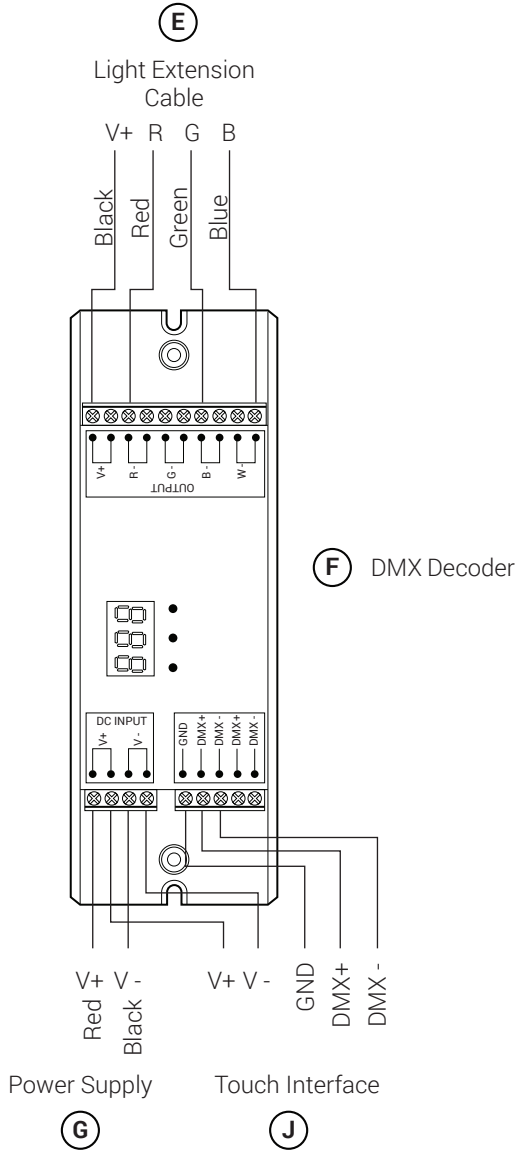

(E)

Light Extension
Cable

V+ R G B

Black
Red
Green
Blue

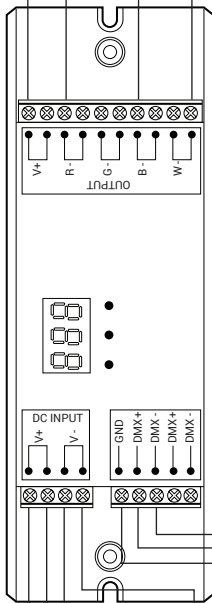

(F) DMX Decoder

V+ V-
Red Black

Power Supply

(G)

V+ V-
GND DMX+
DMX-

Touch Interface

(J)

Spectrum 620-C & 626-C

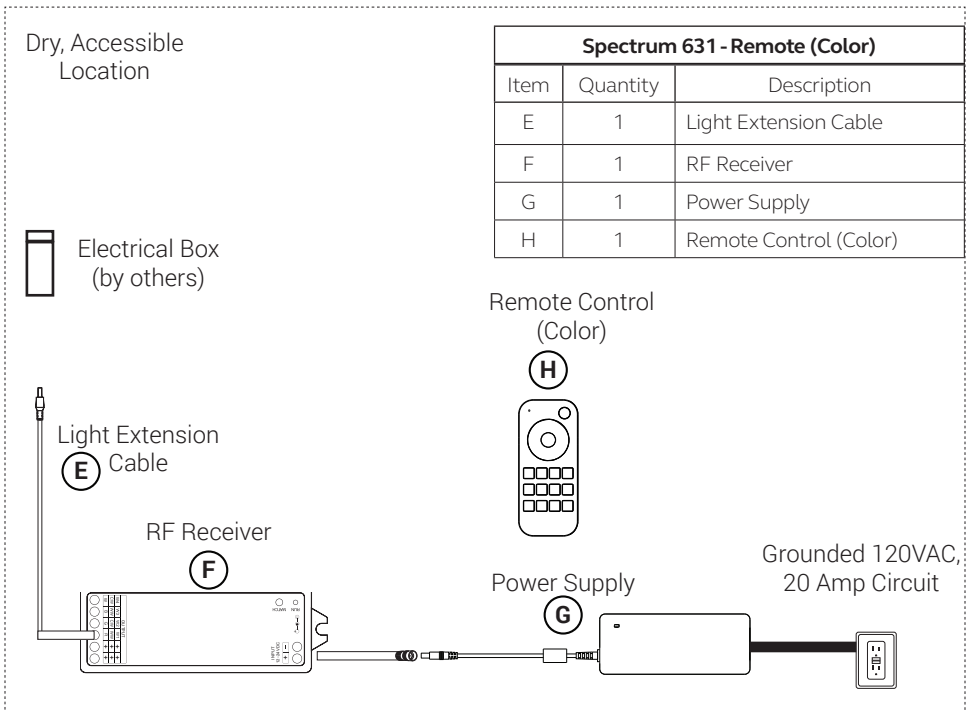
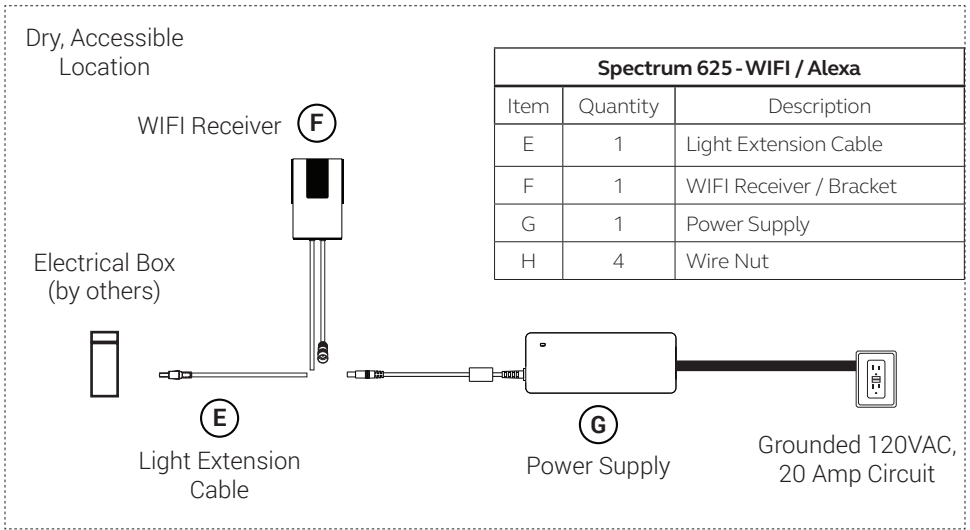

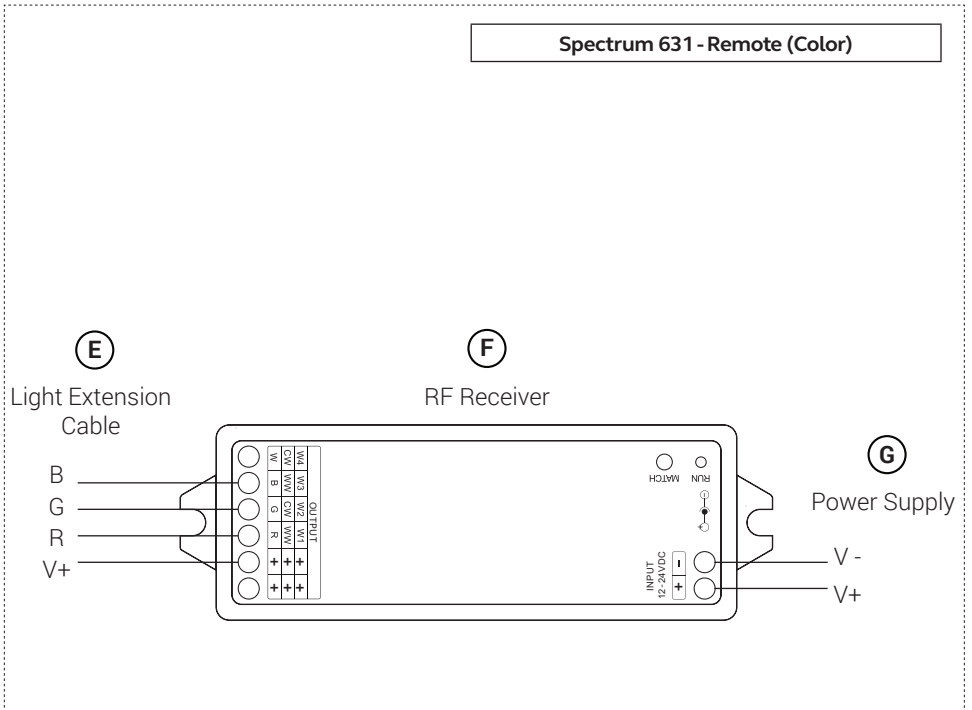
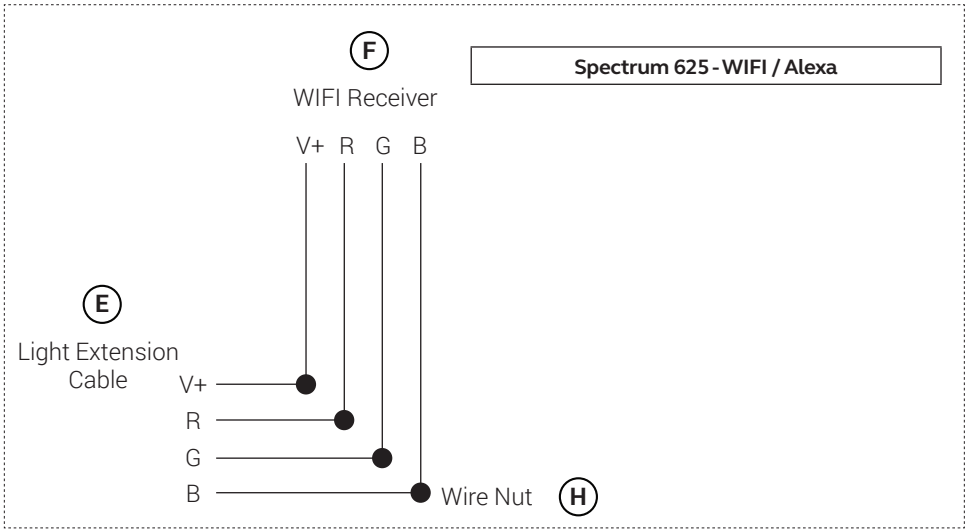

Installation - Himalayan Salt Panel (Interior (Phase 1))

1. Determine the desired locations for the following: Power Supply (G), DMX Decoder (F), Touch Interface (J) and Salt Panel Assembly (A). **Note:** DMX Decoder (F) and Power Supply (G) must be in an accessible, dry location. Provided cord lengths are 50' maximum. DMX Decoder and Power Supply should be located next to each other.

Note: Himalayan Salt Panel Assembly (A) can be recessed or surface mounted.

2. Install electrical boxes for the following: Touch Interface (J), DMX Decoder (F), Power Supply (G), and Salt Panel Assembly (A).
3. Run a 120VAC externally switched GFCI outlet to power electrical box supplying power to Power Supply (G).
4. Connect the following to the DMX Decoder (F): Main Power Cable from Power Supply (G), Power Connector (I), DMX Cable (H), and Light Extension Cable (E). See wiring Diagram.
5. Route DMX Cable (H) and Power Connector (I) to Touch Interface (J) electrical box.
6. Wire DMX Cable (H) and Power Connector (I) to Touch Interface (J). See wiring Diagram.
7. Mount Touch Interface (J) to Touch Interface Electrical box.

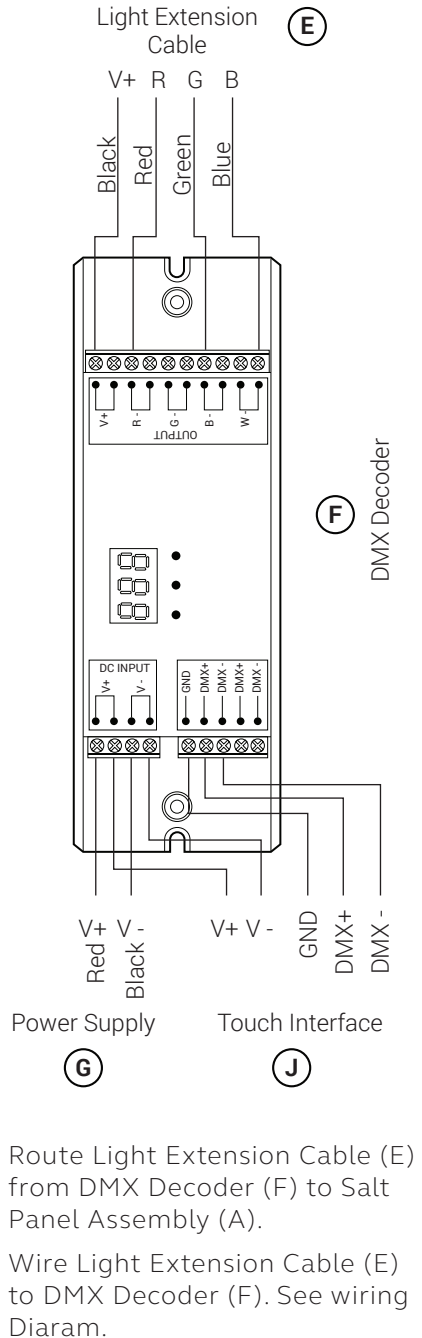

8. Route Light Extension Cable (E) from DMX Decoder (F) to Salt Panel Assembly (A).
9. Wire Light Extension Cable (E) to DMX Decoder (F). See wiring Diagram.

Installation - Himalayan Salt Panel (WIFI (Phase 1))

- Determine the desired locations for the following: Power Supply (G), WIFI Receiver (F), and Salt Panel Assembly (A). **Note:** WIFI Receiver (F) and Power Supply (G) must be in an accessible, dry location. Provided cord lengths are 50' maximum. **Note:** Himalayan Salt Panel Assembly (A) can be recessed or surface mounted.
- Install electrical boxes for the following: Power Supply (G), WIFI Receiver (F), and Salt Panel Assembly (A).
- Run a 120VAC externally switched GFCI outlet to power electrical box supplying power to Power Supply (G).
- Mount WIFI Bracket to wall and place WIFI Receiver (F) into Bracket.
- Route Light Extension Cable (E) from WIFI Receiver (F) to Salt Panel Assembly (A).
- Connect the Light Extension Cable (E) to WIFI Receiver (F), Red-Red, Green-Green, Blue-Blue, Black-Black.
- Connect the WIFI Receiver (F) to the main power cable from Power Supply (G).

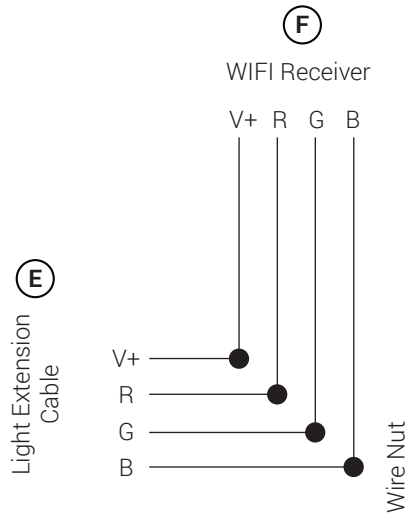

Installation - Himalayan Salt Panel (Remote (Phase 1))

1. Determine the desired locations for the following: Power Supply (G), RF Receiver (F), and Salt Panel Assembly (A). **Note:** RF Receiver (F) and Power Supply (G) must be in an accessible, dry location. Provided cord lengths are 50' maximum. **Note:** Himalayan Salt Panel Assembly (A) can be recessed or surface mounted.
2. Install electrical boxes for the following: RF Receiver (F), Power Supply (G), and Salt Panel Assembly (A).
3. Run a 120VAC externally switched GFCI outlet to power electrical box supplying power to Power Supply (G).
4. Route Light Extension Cable (E) from RF Receiver (F) to Salt Panel Assembly (A).
5. Connect the Light Extension Cable (E) to RF Receiver (F).
6. Connect the RF Receiver (F) to the main power cable from Power Supply (G).

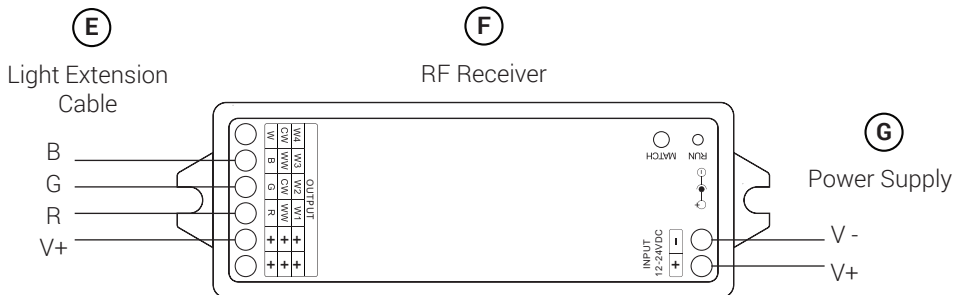

Page left intentionally blank

Installation - Himalayan Salt Panel (Phase 2)

1. From determined Salt Panel Assembly (A) location, mark a level line for height of Salt Panel Assembly (A). (Helpful Tip: Use a piece of 2x4, level and secure to wall at determined height temporarily to be used as a ledger to support Salt Panel Assembly (A))
2. The Salt Panel Assembly (A) fixture may weigh up to 55 lbs. and require additional framework or support. $\frac{3}{4}$ " Plywood is recommended to help support the weight of the fixture(s). See diagram on page 4.
3. Mount Salt Panel Assembly (A) onto wall securing with provided Mounting Screws (C) into predrilled mounting holes.
4. After mounting Salt Panel Assembly (A) slide in 4 Salt Blocks (B) over Mounting Screw (C) locations.
5. Connect Light Extension Cable (E) to Salt Panel Assembly (A) lead to complete assembly.
6. Repeat this process for each additional Himalayan Salt Panel Assembly, if any. A maximum of 3 panel (each 48" x 12") or 7 panel (each 16" x 16") assemblies can be powered by a single control.
7. Each Salt Panel Assembly (A) has 2 connection points. Male and female. Connect male from one panel to female of another for each additional panel.

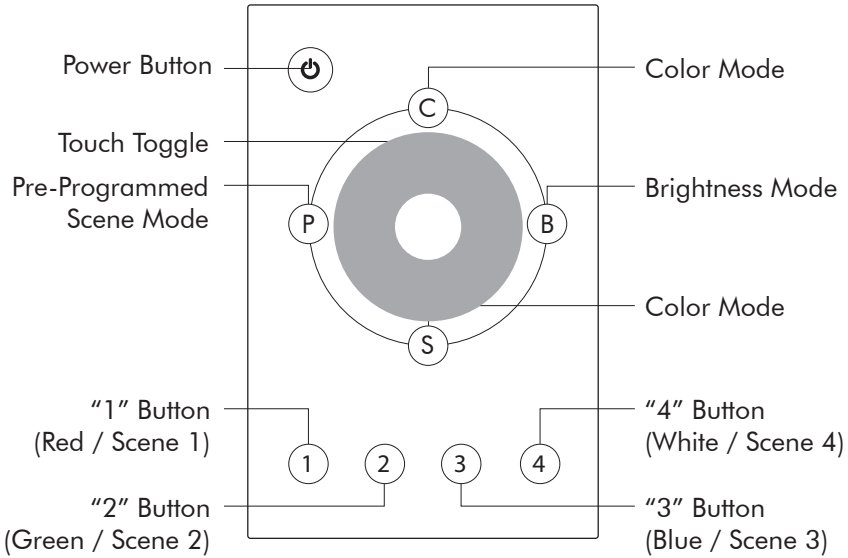
Operation - Interior

Power Button: Press and hold for two seconds to turn the Touch Interface and Salt Light Fixture on or off. Restores most recent settings.

Touch Toggle: Press down on the wheel at any point with your finger to select a color, brightness, or pre-programmed scene depending on which mode you are in. Dragging your finger across the wheel in each mode will result in the following:

- In color mode, shift in color gradually.
- In brightness mode, shift in brightness gradually.
- In pre-programmed scene mode, shift in pre-programmed scene of colors.

Color and brightness are recalled when the control is turned off and on.

Color Mode : Press and hold for two seconds to enable Color Mode.

- 1: Red
- 2: Green
- 3: Blue
- 4: White

Pre-Programmed Scene Mode: Press and hold for two seconds to enable Pre-Programmed Scene Mode.

- 1: Red > Magenta > White > Turquoise > Green > Yellow > White > Magenta > Blue > Turquoise > White > Yellow.
- 2: Red > Yellow > Green > Turquoise > Blue > Magenta.
- 3: Yellow > Turquoise > Magenta.
- 4: Faster version of 1.

Installation - Himalayan Salt Panel (WIFI (Phase 3))

1. In the IOS / Android app store download the Smart Life Smart Living app.
2. Once installed, you can either create an account or tap “Try Now” to continue without creating an account. **Note:** You will need to sign up for an account to be able to use smart home features such as Google or Alexa.
3. Power on WIFI Receiver (F), light should begin to flash on and off rapidly.
4. In the app, select the Blue + symbol in the upper right corner to pair control.
5. Select the “Add Manually” tab at the top, then select “Lighting” tab.
6. Under lighting select “Light Source (Wi-Fi)”. When prompted, enter the WIFI network that you will be using to connect to.
7. Ensure light is flashing rapidly. If not, follow on-screen steps to reset control. Confirm light is blinking then press “Next”. Pairing process will not begin. **Note:** If pairing is unsuccessful the control may not be picking up the WIFI signal. Try repositioning the control.
8. Once pairing is successful, you are all set to program your light.

Operation - WIFI

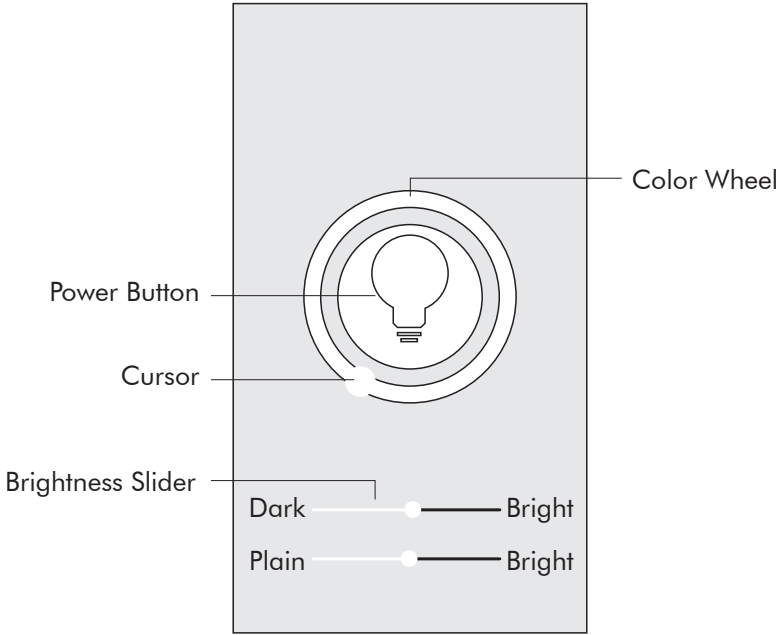

Power Button: Turn on / turn off the Salt Panel Assembly lights. Restores most recent settings.

Color Wheel: Press / drag to change color.

Brightness Slider: Press / drag to change light intensity.

Installation - Himalayan Salt Panel (Remote (Phase 3))

1. Remote should already come paired with receiver. Follow steps below to repair existing remote or new remote.
2. Pairing option 1 - on receiver press the match key then immediately press the On / Off button on the remote.

Pairing option 2 - turn power off then on to receiver then immediately press the On / Off button on the remote. Light should blink 3 times indicating successful pairing.

Operation - Remote

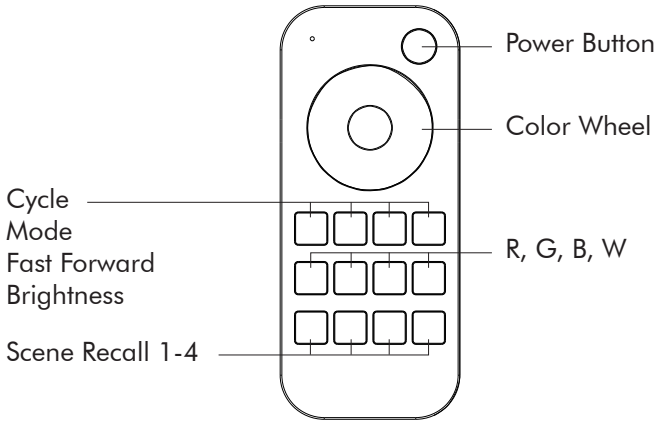

Power Button: Turn on / turn off the Salt Panel Assembly lights. Restores most recent settings.

Color Wheel: Press to change color. Hold for continuous static color adjustment.

Mode: Press to get 24 kinds of static RGB color. Hold for continuous static color adjustment.

Blend: Press to run next dynamic mode. Hold to run mode-cycle.

Fast Forward:
For dynamic RGB mode: Adjusts speed. Press for 10 levels of increased speed. Hold for 2 seconds to set default speed.

For static RGB color: Adjusts saturation. Press for 11 levels of increased mixture of white to current static RGB color. Hold for 1 to 6 seconds for continuous 256 levels adjustment.

Brightness: Press to turn off lights after 30 seconds. Hold for 2 seconds to turn off lights after 60 seconds.

R, G, and B: Press to get Red, Green, and Blue respectively. Press and hold for 1 to 6 seconds to adjust R/G/B brightness continuously to achieve millions of colors.

W: Press to get White (RGB mix). Press and hold for 1 to 6 seconds to adjust saturation continuously, increasing mixture of white to current RGB color.

Scene Recall 1 - 4: Press to recall scene 1, 2, 3, or 4 respectively. Hold for 2 seconds to save current brightness into respective scene (ex: S1 saves to S1). The LED indicator displays green to confirm save.

Specifications - Salt Panel Assembly

Salt Block

Composition: Himalayan Salt

Dimensions: 3-7/8" x 7-7/8"

Himalayan Salt Panel

Dimensions (620-C): 11-5/8"H x 47-1/4"W x 2-5/8"D

Dimensions (626-C): 15-1/2"H x 15-3/4"W x 2-5/8"D

Composition: Maple Plywood, Aluminum

Mounting Screws

Size: #10 x 2-1/2"

LED Light

Operating Voltage: 24VDC

Power Consumption: 33 Watts per panel

Lumens: 924 per Panel

Specifications - Interior Control

DMX Decoder

Operating Voltage: 24VDC

Power Consumption: 192 Watts

Amperage: 4 Channels, 8 Amps

Dimensions: 2.3" x 6.7" x 1.5"

Power Supply

Operating Voltage: 120VAC

Output Voltage: 24VDC

Power Composition: 120W

Nominal Amperage: 5A / 120V

Dimensions: 2"W x 7"D x 1-1/4"H

Power Cable: 2-Wire, #18 AWG, 6" Long

Touch Interface

Operating Voltage: 24VDC

Housing: Aluminum Housing Glass Panel

Load: 2A per Channel, 6A Total

Dimensions: 3-3/16"W x 4-7/8"H x 11/16"D

Replacement Parts

Contact your Bathology representative for Spectrum 620-C / 626-C Color Light Salt Panel replacement parts.

800-957-2862

www.Bathology.com

Specifications - WIFI Control

WIFI Receiver

Operating Voltage: 24VDC

Power Consumption: 144 Watts

Amperage: 3 Channels, 5 Amps

Dimensions: 2.29”H x 1.21”W x .34”D

Power Supply

Operating Voltage: 120VAC

Output Voltage: 24VDC

Power Composition: 120W

Nominal Amperage: 5A / 120V

Dimensions: 2.6” x 6.5” x 1.3”

Connector: 24VDC, 50’

Specifications - Remote Control

Power Supply

Operating Voltage: 120VAC

Output Voltage: 24VDC

Power Composition: 120W

Nominal Amperage: 5A / 120V

Dimensions: 2.6” x 6.5” x 1.3”

Connector: 24VDC, 50’

RF Receiver

Input Voltage: 12-24VDC

Input Current: 15.5A

Output Voltage: 4x (12-24VDC)

Output Current: 4CH,4A/CH, Max 6A

Output Power: 4 x (48 x 96)W

Output Type: Constant Voltage

Remote

Output Signal: RF (2.4 GHz)

Working Voltage: 3VDC (AAA x2)

Remote Distance: 30m (Barrier-free space)

BATHOLOGY

rediscover bathing

www.Bathology.com 800-957-2862

A division of Bathing Brands, Inc.